

Compressed Air System Design

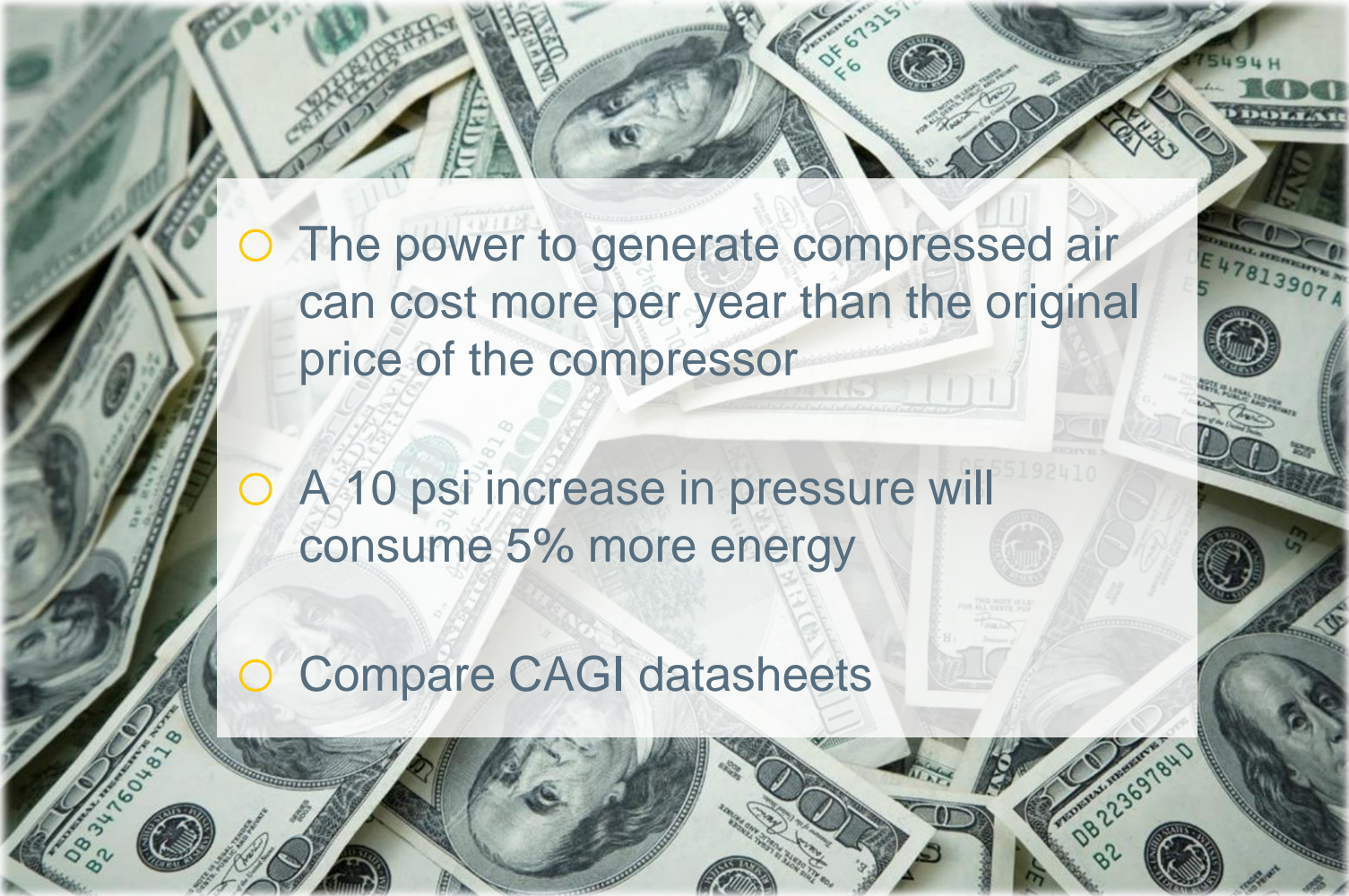

Greg Ashe, Key Account Manager

What Does Compressed Air Cost?

- 
- The power to generate compressed air can cost more per year than the original price of the compressor
 - A 10 psi increase in pressure will consume 5% more energy
 - Compare CAGI datasheets

Compressor Room Temperature

Temperature range should be 40 – 115°F. Cooler is better!

Compressor rooms with ambient temperatures below 40°F may require special fluids or equipment modifications.

Compressor rooms with ambient temperatures above 105°F:

- Increase internal operating temperature
- Require more frequent fluid and filter changes
- Result in more liquid moisture downstream
- Require larger dryers

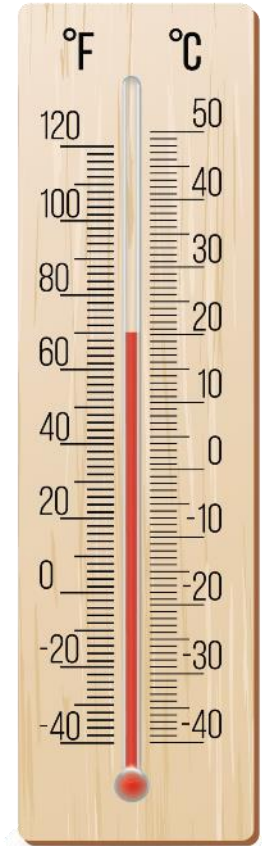

Compressor Installation

- Compressor location affects performance and longevity
- Air quality and compressor reliability are directly impacted by the environment
- Avoid high dirt and high dust areas
- Allow space around the compressor for service



Compressor Room Ventilation



Fluid Injected Screw Compressors

Generic design:

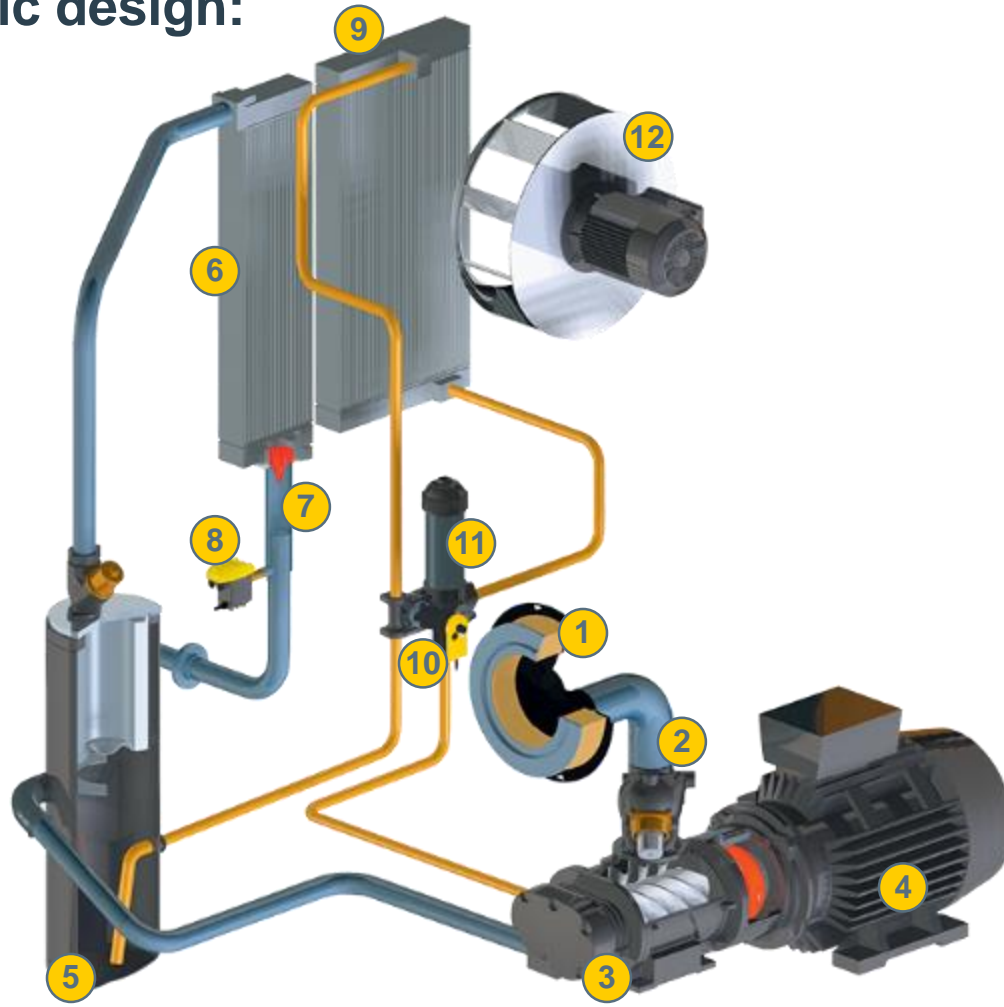

- ① Intake filter
- ② Inlet valve
- ③ Airend
- ④ Drive motor
- ⑤ Fluid separator tank
- ⑥ Compressed air aftercooler
- ⑦ Integral moisture separator
- ⑧ Condensate drain (Eco-Drain)
- ⑨ Fluid cooler
- ⑩ Electronic Thermal Management (ETM) system
- ⑪ Fluid filter
- ⑫ Radial fan

Right Sizing is Critical!

Under sizing:

- Low and unstable system pressure
- Lack of back-up
- Process fluctuations and shutdowns
- Product quality fluctuations

Over sizing:

- Excessive energy consumption
- Low operating temperature
- Excessive motor starts
- Rapid cycling

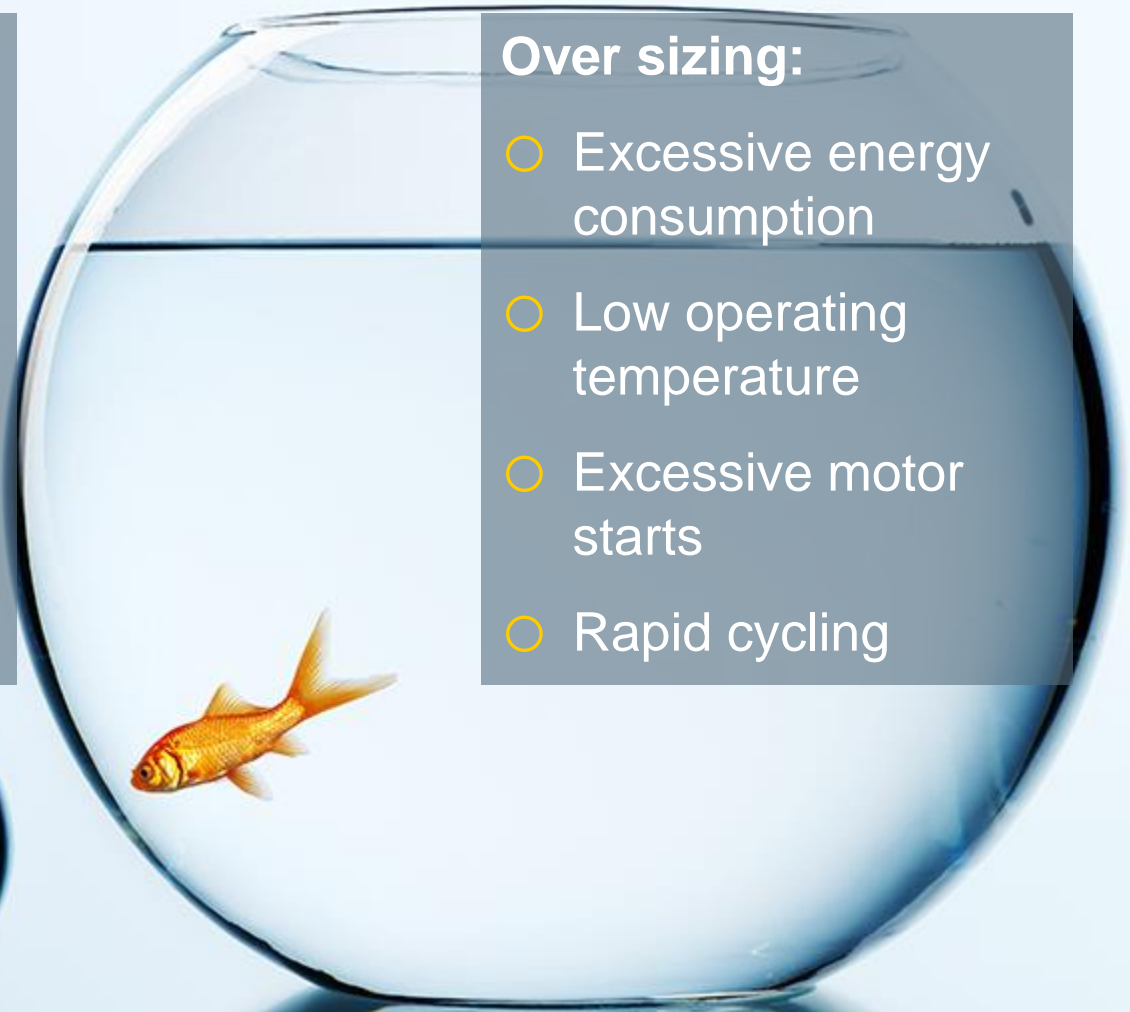

Minimum Information Needed



Pressure requirements (psig) of pneumatic tools and equipment

Flow requirements (cfm) of pneumatic tools and equipment

Utilization rate (load factor) of each piece of equipment – average total utilization factor

Air quality requirements

Ambient compressor room conditions



System Design

1. **Compressor room/pad connection:** connects air receivers with the main network
2. **Main network:** distributes the compressed air within the consumer network
3. **Branch lines:** between main network and point of use

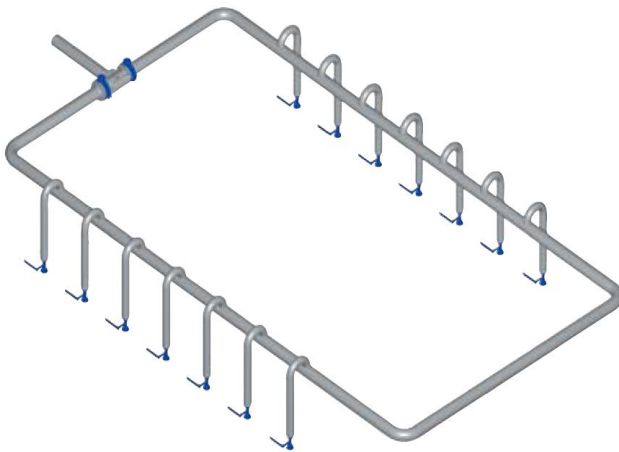

Ring Main/Looped Piping Network

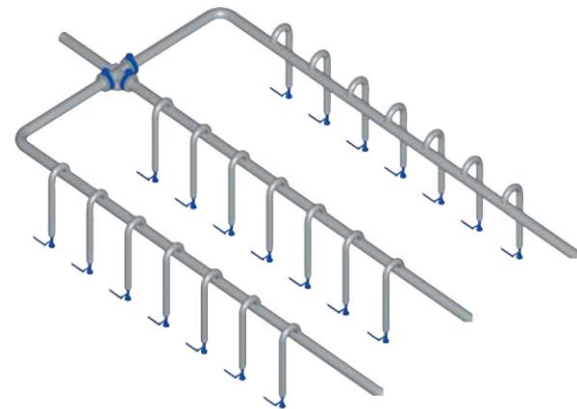

Branched Piping Network

System Design

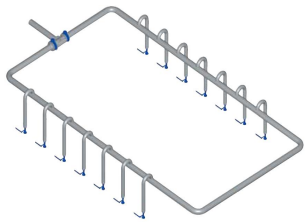

**Ring
Main/Looped
Piping
Network**

- **Advantages:**
 - **Lower pressure drop**
 - **Piping provides additional storage**
 - **Feeds from two directions**
- **Disadvantages**
 - **Higher Cost**

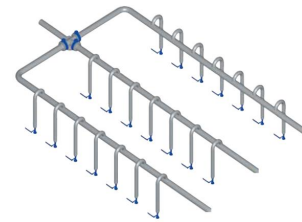

**Branched
Piping Network**

- **Advantages:**
 - **Lower cost**
 - **Easy to isolate sections**
- **Disadvantages:**
 - **Higher pressure drop possible**
 - **Feeds from only one direction**

Compressed Air Piping

Compressed air velocity should be kept to:

- 15 feet per second in the compressor room
- 30 feet per second in the main header
- 45 feet per second in the air drops

Rule of thumb:

A well designed piping system will have less than a 2 psi pressure drop in the entire system, not counting air treatment equipment



Line Loss and Pressure Drop

- Interior pipe texture determines friction and line loss
- Rough surfaces cause turbulent air flow and pressure drop
- High coefficient of friction reduces velocity and increases pressure drop

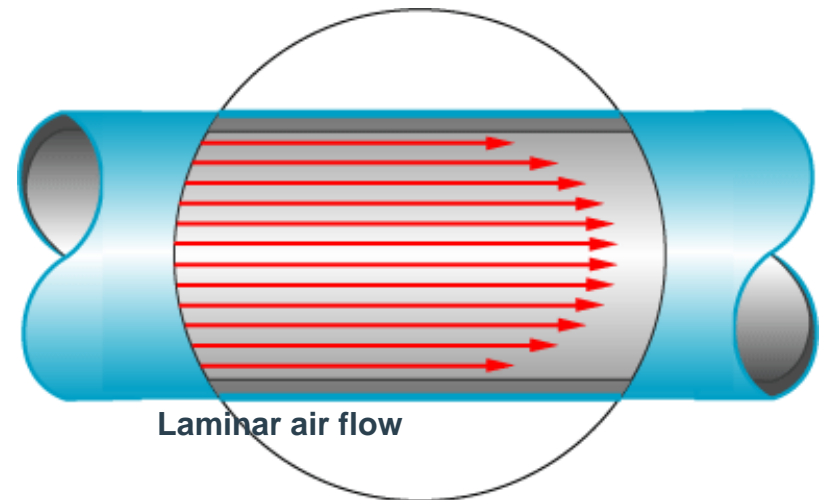
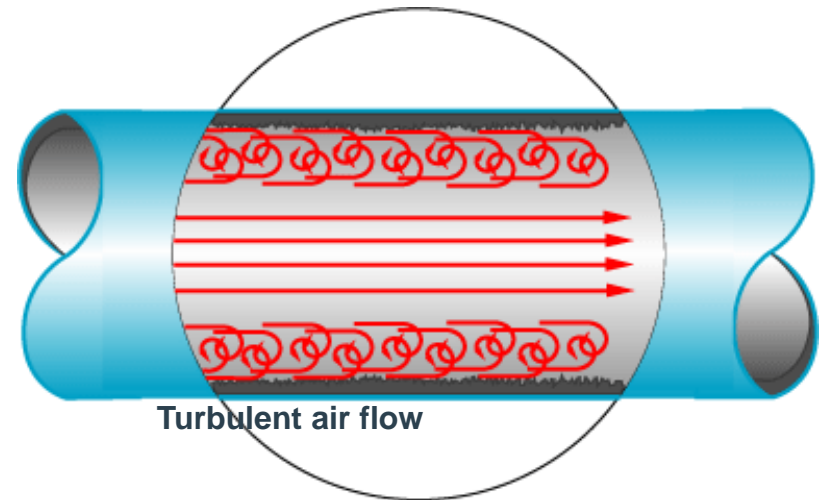

Line Loss and Pressure Drop (Continued)

- Traditional piping systems (steel, black iron) develop corrosion
- Pressure drops in piping force compressors to work harder
- Causes of line loss and pressure drop:
 - Improperly sized air pipe
 - Inefficient pipe layout
 - Pipe scale and corrosion
 - Piping material
 - Air leaks



Corroded traditional piping system components

Piping Material Options

Material	Advantages	Disadvantages
Black Iron	<ul style="list-style-type: none"> • Moderate material costs • Available in multiple sizes 	<ul style="list-style-type: none"> • Labor intensive installation • May rust and leak • Rough inside promotes contaminant build up and creates pressure drop
Galvanized Iron	<ul style="list-style-type: none"> • Moderate material costs • Available in multiple sizes • Some rust protection 	<ul style="list-style-type: none"> • Often exterior is coated • Labor intensive installation • Rough inside promotes contaminant build up and creates pressure drop • May rust at joints and leak
Copper	<ul style="list-style-type: none"> • No rust, good air quality • Smooth interior—low pressure drop 	<ul style="list-style-type: none"> • Requires quality brazing to prevent leaks • Susceptible to thermal cycling • Installation requires open flame
Stainless Steel	<ul style="list-style-type: none"> • No rust, good air quality • Smooth interior—low pressure drop 	<ul style="list-style-type: none"> • Labor intensive installation • Expensive materials
PVC	<ul style="list-style-type: none"> • Lightweight • Inexpensive 	<ul style="list-style-type: none"> • Lower safety • In certain areas, not compliant with certain codes • Carries static charge • Subject to bursting • Adhesives not compatible with compressor oils
Aluminum	<ul style="list-style-type: none"> • Corrosion resistant • Lightweight • Easy to install • Lower cost of ownership 	<ul style="list-style-type: none"> • Limited pressure ratings • Material costs

Prevention of Pressure Drops

Pressure drop is caused by:

- Insufficient dimensioning of the compressed air pipe
- Non-linear course of the compressed air pipe
- Connections and joints
- Turbulence
- Very long pipelines
- Friction at the walls



Efficiency losses of a tool due to pressure drop

Working pressure psig	Available output	
	%	kW
85	100	3.0
80	86	2.6
70	74	2.2
65	62	1.9
60	52	1.6

Pressure drop **reduces** the **output** of the compressed air consumer and/or **increases** the **costs** of compressed air generation and hence production!

Receiver Tanks



- Sizing receivers – total storage should be at least 4 to 6 gallons per cfm of the cycling compressor's capacity
- Storage can be shared with multiple tanks and piping
- Pressure rating must exceed highest system pressure
- Must have safety relief valves sized for pressure and total flow
- Pipe in low and out high to prevent liquid carry-over
- Large automatic drains on wet tanks

Drain Traps

- Types:

- Manual
- Timed electric traps

- Demand traps

- Float actuated
- Electronic capacitance



Manual



Timed Electric



Magnetic Float



Electronic Capacitance

Dryer Installed Downstream of Air Receiver

○ Advantages:

- Facilitates efficient compressor control (avoids excessive cycling)
- Dryer can be specified for partial air flow
- Lower dryer inlet temperature
- 70% of the condensate is separated in the air receiver or in the centrifugal separator

○ Disadvantages

- Dryer can be overloaded with sudden large air demands



Dryer Installed Upstream of Air Receiver

○ Advantages:

- Dry air in the receiver
- Demand surge does not overwhelm the clean air treatment system

○ Disadvantages:

- Higher dryer inlet temperature
- Excess liquid loading of the dryer possible
- Excessive cycling of the compressor is possible
- Partial air drying not possible



Compressed Air System Layout

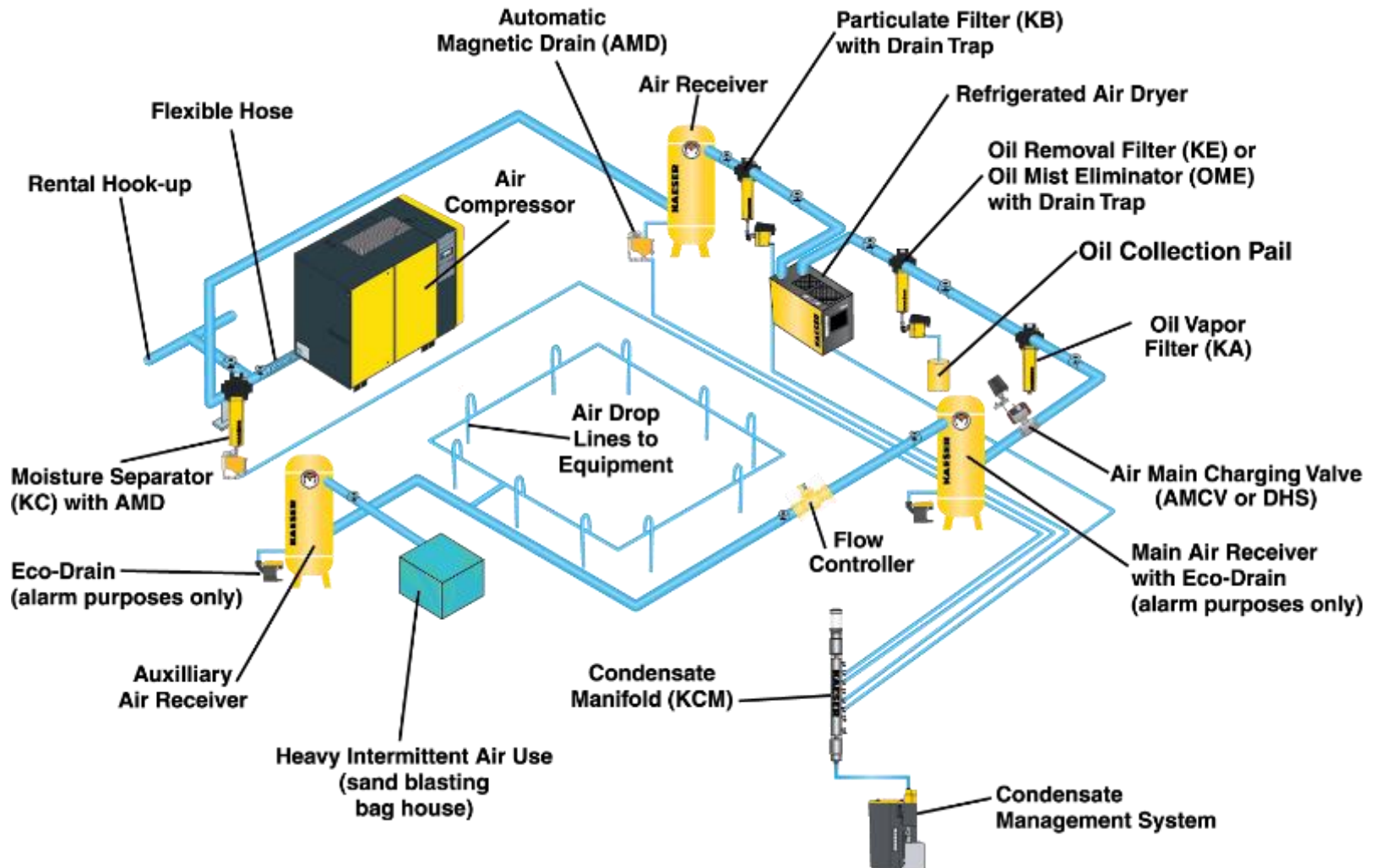

ISO 8573-1

Purity Classes of Compressed Air

SOLID PARTICLES / DUST			
If particles greater than 5µm have been measured, class 0-5 cannot be applied			
Class	0.1 - 0.5 µm	0.5 - 1 µm	1 - 5 µm
0	As specified and more stringent than Class 1		
1	≤ 20,000	≤ 400	≤ 10
2	≤ 400,000	≤ 6000	≤ 100
3	---	≤ 90,000	≤ 1000
4	---	---	≤ 10,000
5	---	---	≤ 100,000
6	≤ 5 mg/m ³		
7	5.. - 10 mg/m ³		
8			
9			
X	> 10 mg/m ³		

HUMIDITY AND LIQUID WATER		
Class	Pressure Dew Point	
0	As specified and more stringent than Class 1	
1	≤ -70°C	≤ -94°F
2	≤ -40°C	≤ -40°F
3	≤ -20°C	≤ -4°F
4	≤ 3°C	≤ 38°F
5	≤ 7°C	≤ 45°F
6	≤ 10°C	≤ 50°F
Concentration of liquid water		
7	≤ 0.5 g/m ³	
8	0.5 - 5 g/m ³	
9	5 - 10 g/m ³	
X	≥ 10 g/m ³	

TOTAL OIL		
Liquid, aerosol, and vapor		
Class	mg/m ³	ppm w/w
0	As specified and more stringent than Class 1	
1	≤ 0.01	≤ 0.008
2	≤ 0.1	≤ 0.08
3	≤ 1.0	≤ 0.8
4	≤ 5.0	≤ 4
5		
6		
7		
8		
9		
X	> 5.0	> 4

Reference conditions: 68°F (20°C), 14.5 psia (1 bar), 0% relative humidity

Refrigerated Dryers

- For systems with an aftercooler
 - Inlet temp approx. 100°F
- Achieve 35° - 50°F dew points
- Often have filters and automatic drains built in



Desiccant Dryer Types Defined

2 types of desiccant dryers – “heatless” and “heated”



Heatless



Heated

Example Air Treatment Configurations

ISO 8573.1 Quality Class: 3.4.4

Examples:
General Shop Air
Air Tools
Sand Blasting

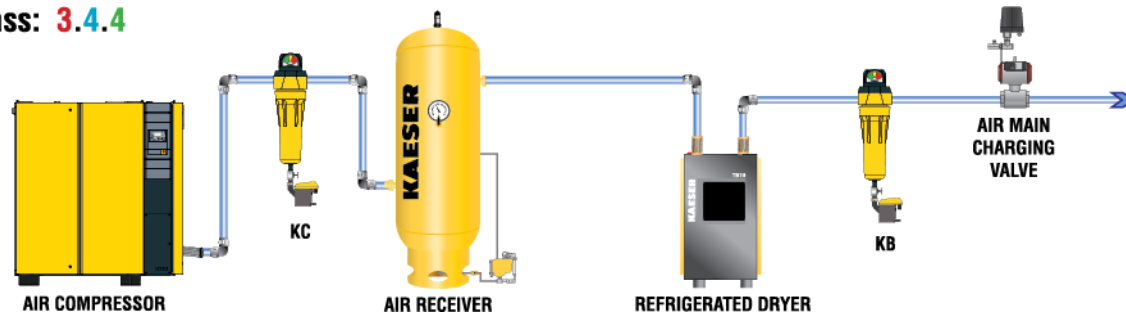

ISO 8573.1 Quality Class: 1.4.1

Examples:
Food and Beverage
Laboratories

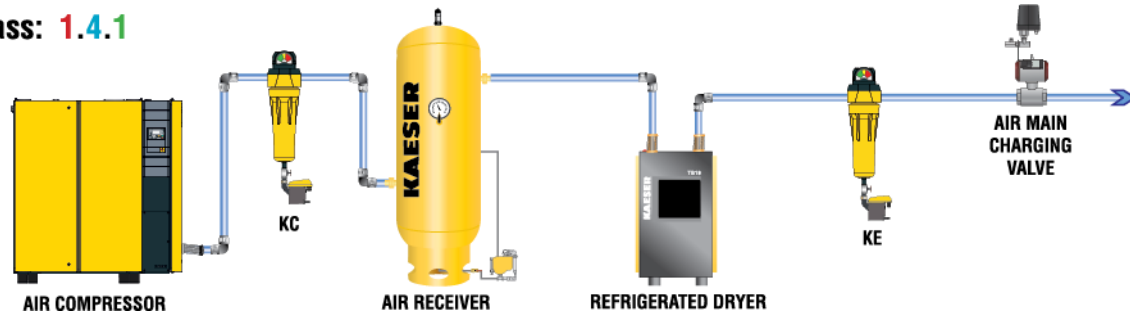

ISO 8573.1 Quality Class: 1.2.1 or 1.1.1

Examples:
Food and Beverage
High-tech Clean Rooms
Pharmaceutical
Chemical Industries
Laboratories

