



Electrification in Colorado in 2022: Design Considerations for Plumbing Engineers

February 16, 2022

Bobby Henderson

LONG Building Technologies

You want me to Electrify what now??

- State Level
- City of Denver
- Other Jurisdictions
- Heat Pump Technology

You want me to Electrify what now??

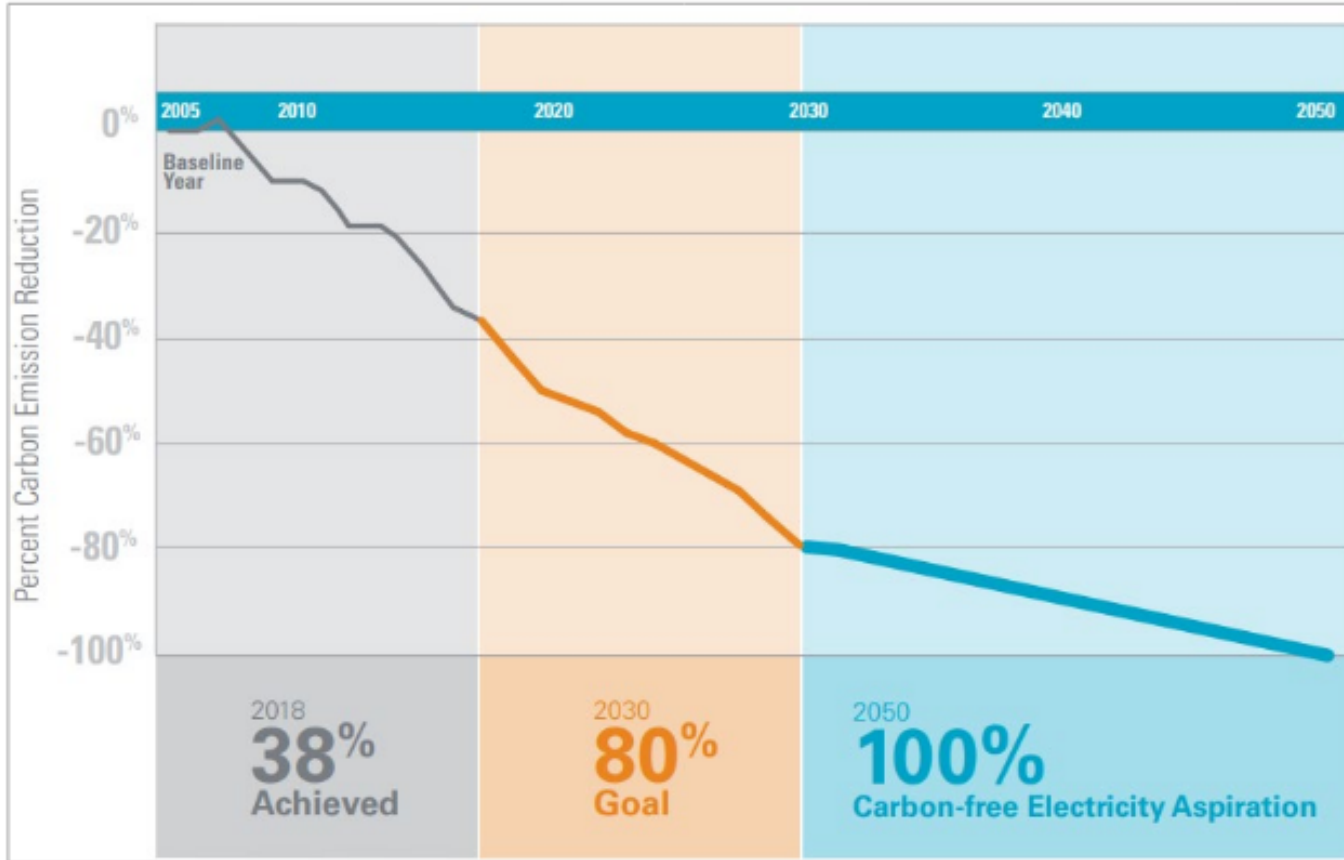

[Source: Xcel Energy Carbon Report](#)

Figure 4. Xcel Energy Carbon Reduction Trajectory: Clean Energy Transition 2030 and 2050



May 30, 2019

HB19-1261 - Climate Action Plan To Reduce Pollution

(g) ACCORDINGLY, COLORADO SHALL STRIVE TO INCREASE RENEWABLE ENERGY GENERATION AND ELIMINATE STATEWIDE GREENHOUSE GAS POLLUTION BY THE MIDDLE OF THE TWENTY-FIRST CENTURY AND HAVE GOALS OF ACHIEVING, AT A MINIMUM,

A TWENTY-SIX-PERCENT REDUCTION IN STATEWIDE GREENHOUSE GAS POLLUTION BY 2025, A FIFTY-PERCENT REDUCTION IN STATEWIDE GREENHOUSE GAS POLLUTION BY 2030, AND A NINETY-PERCENT REDUCTION IN STATEWIDE GREENHOUSE GAS POLLUTION BY 2050.

THE REDUCTIONS IDENTIFIED IN THIS SUBSECTION (2)(g) ARE MEASURED RELATIVE TO 2005 STATEWIDE GREENHOUSE GAS POLLUTION LEVELS.



- **Colorado GHG Pollution Reduction Roadmap – Published 2019**

2020 CO GHG Emissions (MMT CO₂e, AR5 100-yr GWP)

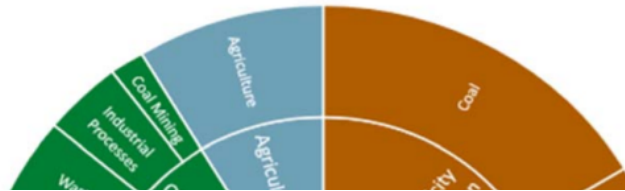

- Electrification of end uses in buildings and transportation will play an important role in achieving these targets, with action needed in the near term to accelerate the transition.

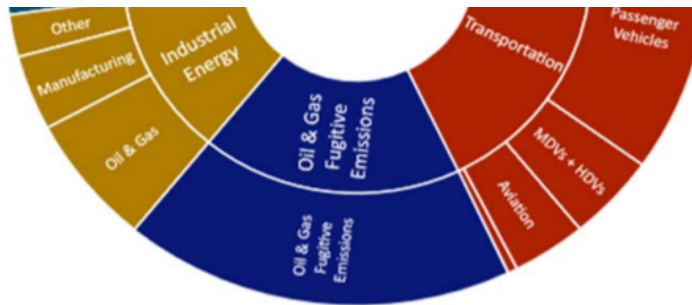



- **Colorado GHG Pollution Reduction Roadmap – Published 2019**

<p>Residential, Commercial, and Industrial Fuel Use (Gas utilities)</p>	<ul style="list-style-type: none"> • Expand energy efficiency investments from gas utilities to support improv • Set carl biogas i utilities • Require building make p polluti • Support building • Require regulated electric utilities to create programs that support customer adoption of electric 	<ul style="list-style-type: none"> • Require regulated electric utilities to create programs that support customer adoption of electric 	<p>heat pumps and other forms of beneficial electrification.</p> <p>to financing building retrofits by ree bank, ting programs and utility on-bill ms.</p> <p>i industrial energy audits requirements ble Control</p> <p>technology requirements, setting the stage for future performance requirements.</p>	
---	---	---	--	--



January 2021 – Net Zero Energy Buildings and Homes Report

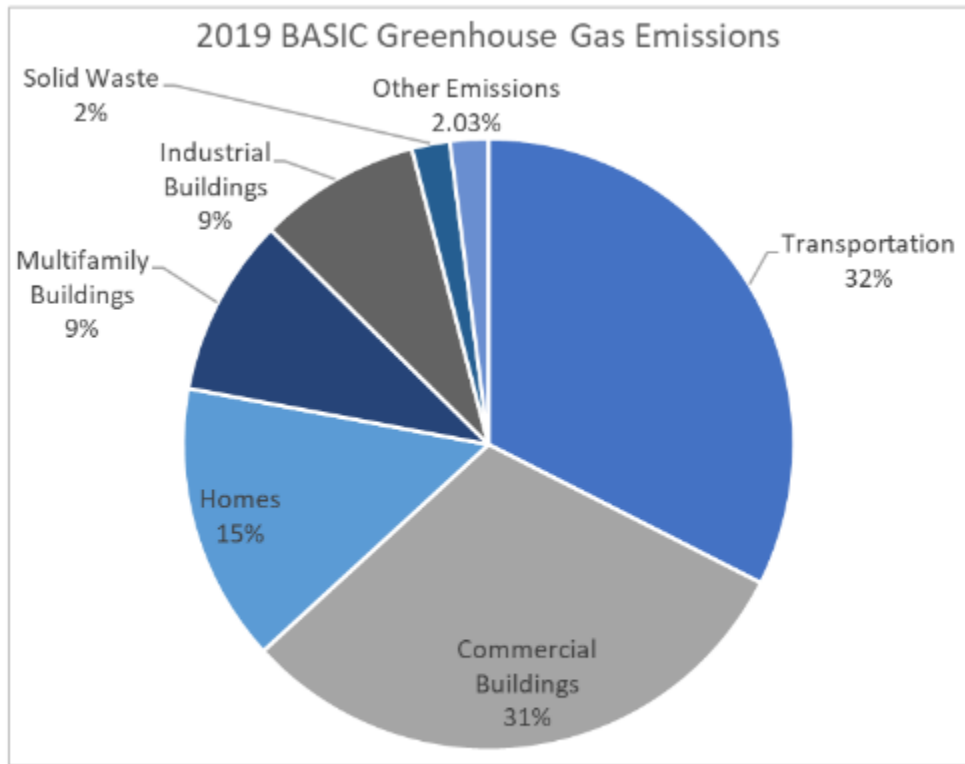

Source: CASR

Figure 2. 2019 BASIC GHG Emissions in Denver



Office of Climate Action,
Sustainability, and Resilience
(CASR)

January 2021 – Net Zero Energy Buildings and Homes Report

- Net zero energy, all-electric new homes in the 2024 Building Code
- Net zero energy, all-electric new buildings in the 2027 Building Code
- New buildings perform as designed with performance verification in the 2030 Building Code

Commercial	2021	2024	2027	2030
HIGHLY EFFICIENT				
Energy Modeling Accuracy	Report on discrepancy in disclosure data	Within 15% of target	Within 10% of target	Achieve target
ALL-ELECTRIC				
Equipment requirement	<u>All-Electric:</u> <i>except heating & water heating</i> <u>All-Electric Ready:</u> <i>conduit for central</i>	<u>All-Electric:</u> <i>except water heating</i>	All-electric equipment	All-electric equipment
RENEWABLE ENERGY				
Minimum renewable offset	50%	75%	100%	100%
GRID FLEXIBILITY				
Grid flexibility requirement	Grid Flexible Equipment	Implementation of Grid Flexible Metric	Improving Grid Flexibility + Increased Storage	Improving Grid Flexibility + Increased Storage



January 2021 – Net Zero Energy Buildings and Homes Report

Table 11. Commercial Building All-Electric Targets for Denver Code

Building Type	2021	2024	2027
Small Hotel	All-Electric:		

Table 16. Building and Home Grid Flexible Requirements for Denver Code

	2021	2024	2027
All Buildings & Homes	Grid Flexible Equipment	Implementation of Grid Flexible Metric	Improving Grid Flexibility + Increased Storage

Table 12. Multifamily Building All-Electric Requirements for Denver Code

Building Type	2021	2024	2027
3-story townhome & Low-Rise Apartment	Required	Required	Required
Mid-Rise Apartment (R-2: 4-7 stories)	All-Electric Ready: conduit & panel space	Required	Required
High-Rise Apartment (R-2: 8 or more stories)	All-Electric Ready: conduit & panel space	All-Electric Ready: conduit & panel space	Required

Table 13. Residential Home All-Electric Targets for Denver Code

Building Type	2021	2024
Single-family Homes	All-Electric Ready: conduit & panel space	Required



Timeline:

- November 2021 – Energize Denver Bill

BY AUTHORITY

ORDINANCE NO. 20211310

SERIES OF 2021

COUNCIL BILL NO. CB21-1310

COMMITTEE OF REFERENCE:

Safety, Housing, Education, & Homelessness

A BILL

For an ordinance amending the Revised Municipal Code of the City and County of Denver to require energy performance and greenhouse gas emissions reductions in existing commercial and multifamily buildings and future electrification requirements for existing buildings.



Timeline:

- November 2021 – Energize Denver Bill

(8) Exemptions for emergency replacement and economic hardship shall be provided. An economic hardship exemption will not be available for a system that can be replaced with an electric heat pump at near cost parity, which will be defined as the cost of a replacement of a natural gas space or water heating system to a partially electric heat pump system, including all incentives, that is within 5-15% of a like-for-like natural gas space or water heating system replacement, including the social cost of carbon dioxide of the like-for-like gas system replacement over its lifetime. An economic hardship exemption will not be available for a system where a heat pump is unavailable and where the cost of an electric resistance system is at 'near cost parity' for that system type, which will be defined as the cost of an electric resistance system, including all incentives, that is within 5-15% of a like-for-like gas system replacement plus the social cost of carbon of that like-for-like system over its lifetime. The building official shall consult with the executive director of the office of climate action, sustainability, and resiliency in deciding whether or not to approve an economic hardship exemption.



February 2022 – Code Adoption Technical Advisory Committees

Summer 2022 – Public Comment before Legislative Process

Other Jurisdictions

City of Boulder

- **Net Zero new Commercial buildings by 2031, working with individual developers for incentives**
- **2023 code update upcoming**

City of Louisville

- **Adoption of IEC 2021 – Requiring “Electric Ready” buildings**

Other States (WA, CA, NY)

OK, OK, let's talk
about heat PUMPS



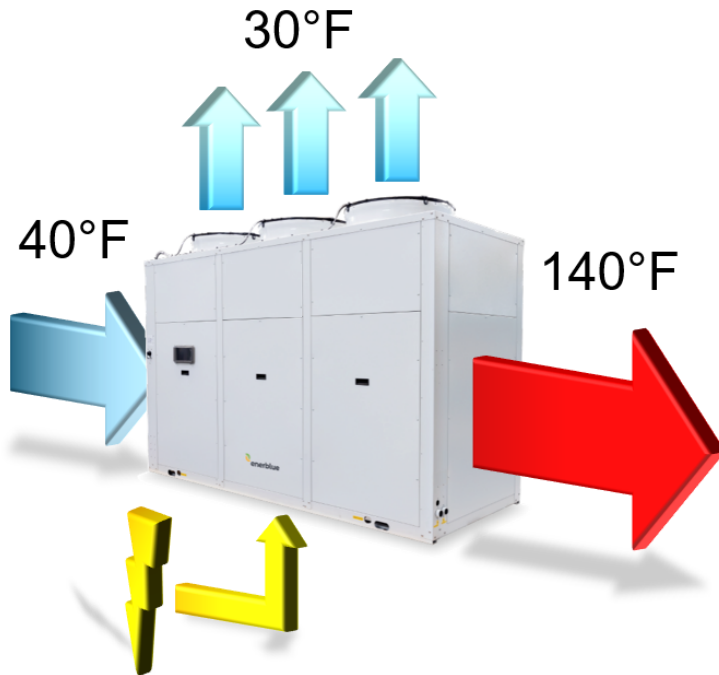

$$COP = \frac{\textit{Heat Out}}{\textit{Electricity In}}$$

Storage Heat Pump Water Heaters

Air-Source



- Lower COP's (up to 4.0 UEF)
- Air Flow and Noise Requirements may constraint application
- Typically R-134
- Limited Sizes
- Limited Ambient Operating Conditions

SPLIT SYSTEM HEAT PUMPS

Air-Source

Water-Source

Waste-Water Source



Available Refrigerants:

- R-134
- R-513
- R-744 (CO₂)

Heat Pump Water Heater Design Options

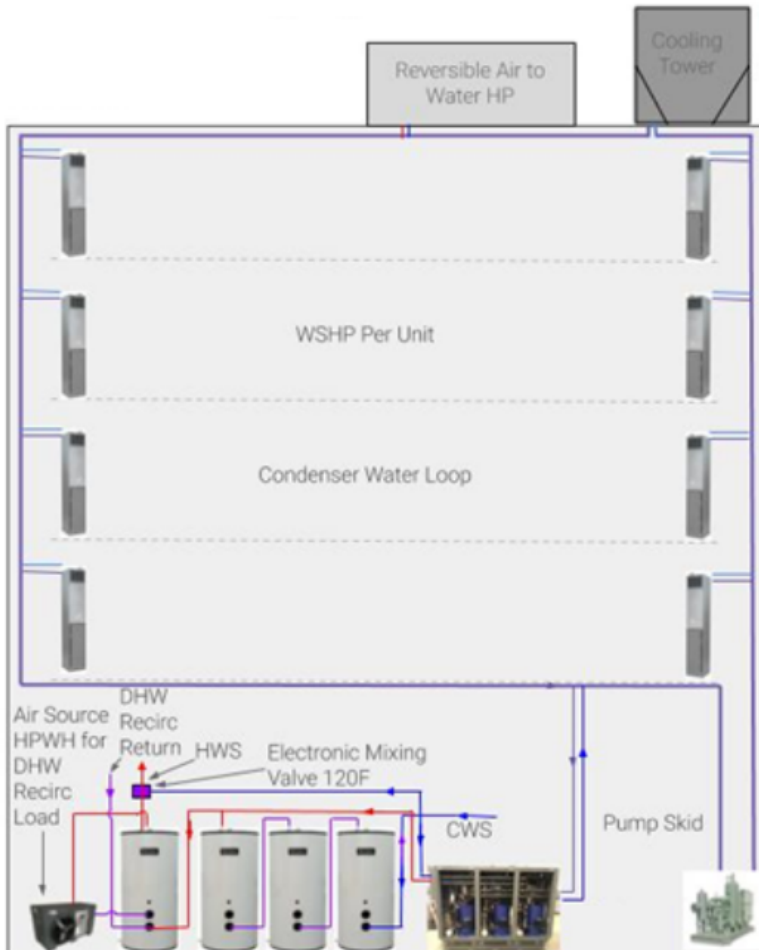

Water-Source DHW Heat Pump

- Higher COP's
- Flexible Condenser Water Temperatures
- R-134, 513, 744
- Higher Installed Cost
- Will likely require electric boiler backup for condenser water heat

Heat Pump Water Heater Design Options

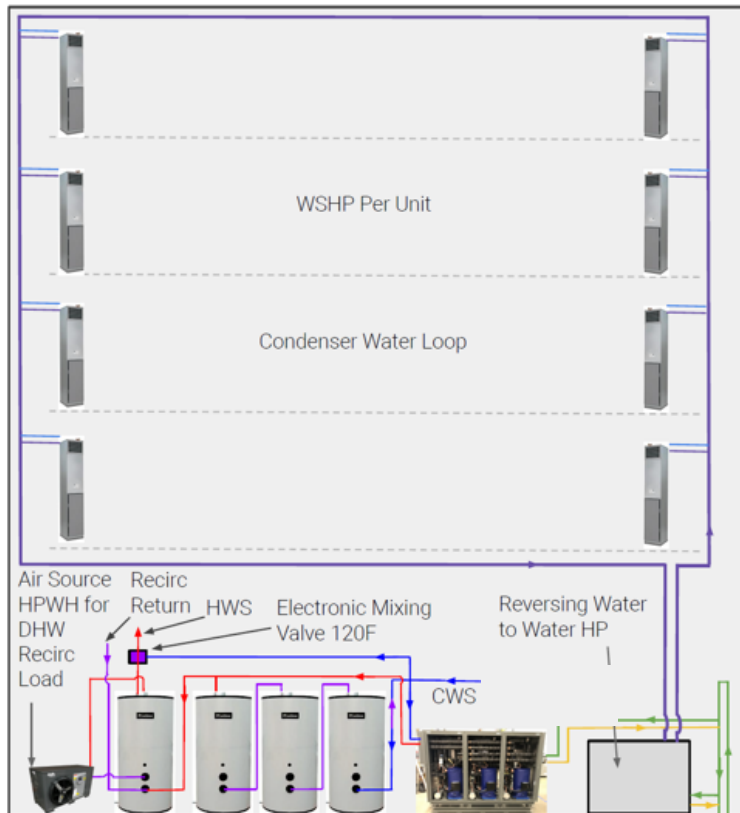

Ground-Source DHW Heat Pump

- Higher COP's (up to 5.5)
- Flexible Condenser Water Temperatures
- R-134, 513, 744
- Ground-Source projects carries higher installation costs

Heat Pump Water Heater Design Options

Air-Source DHW Heat Pump

- COP's up to 5.0
- COP's very dependent on Ambient Conditions
- Freeze Protection Required
- R-134, 513, 744

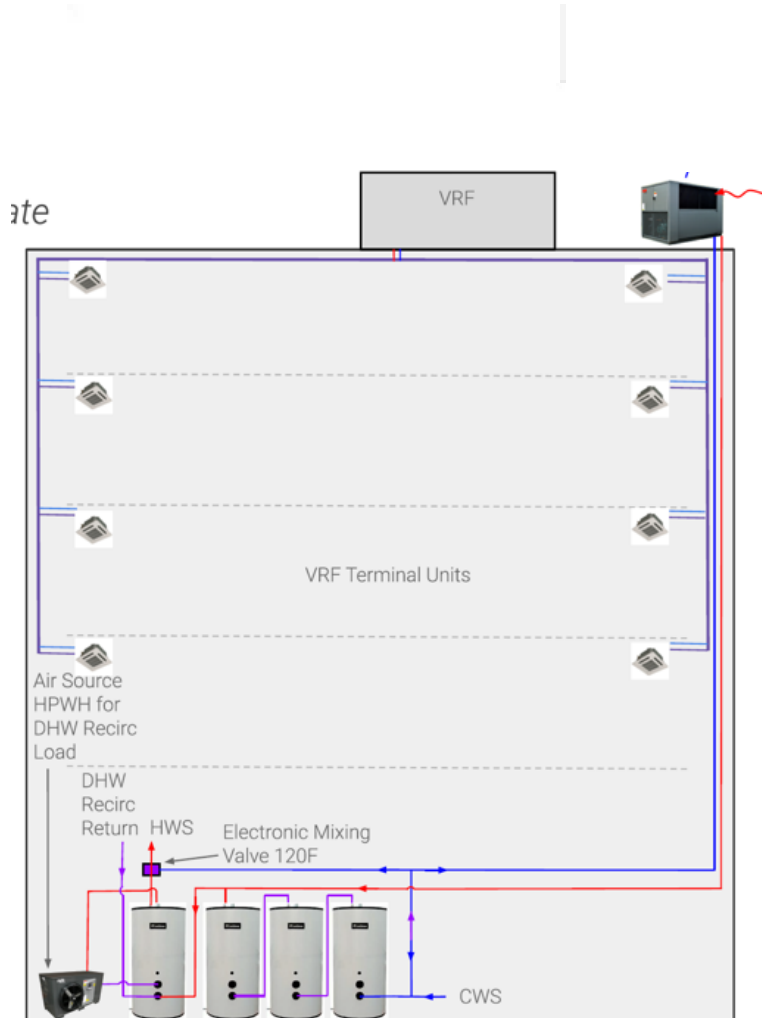

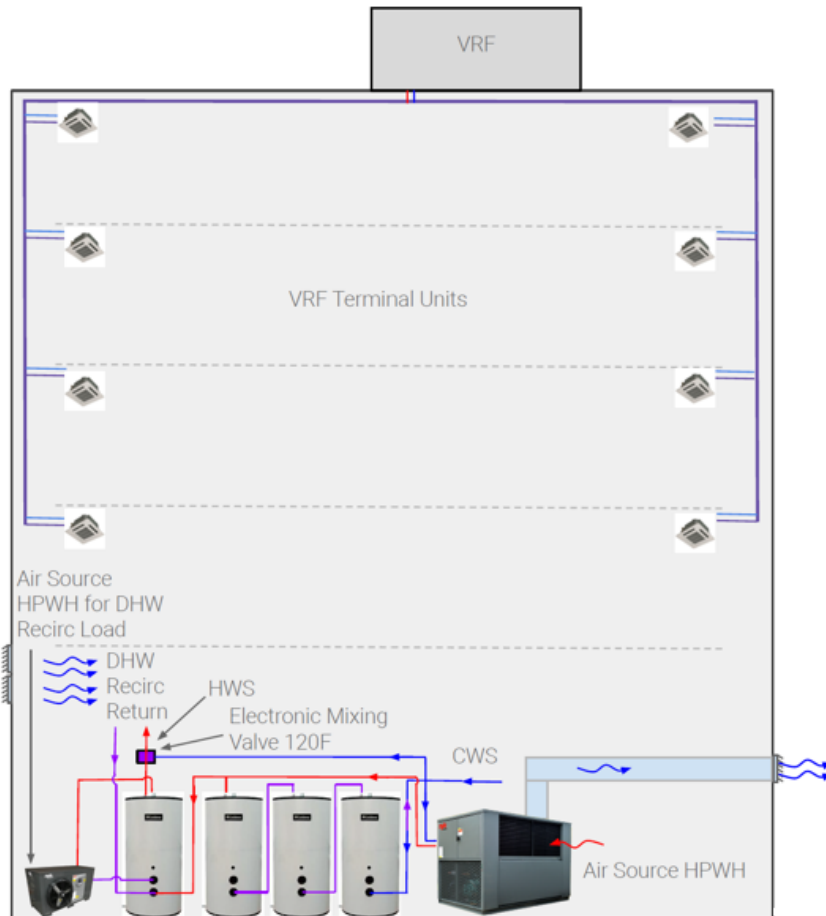

Air-Source (Ducted) DHW Heat Pump

- COP's up to 5.0
- COP's less dependent on Ambient Conditions
- High Airflow Requirements
- Freeze Protection May Still be Required
- R-134, 513, 744
- May not meet IECC code (pending amendments)

Wastewater-Source DHW Heat Pump

- COP's up to 5.0
- Less Reliant on Ambient Air Conditions
- Unfamiliarity in the marketplace
- Freeze Protection May Still be Required
- R-513
- May qualify for high IECC points

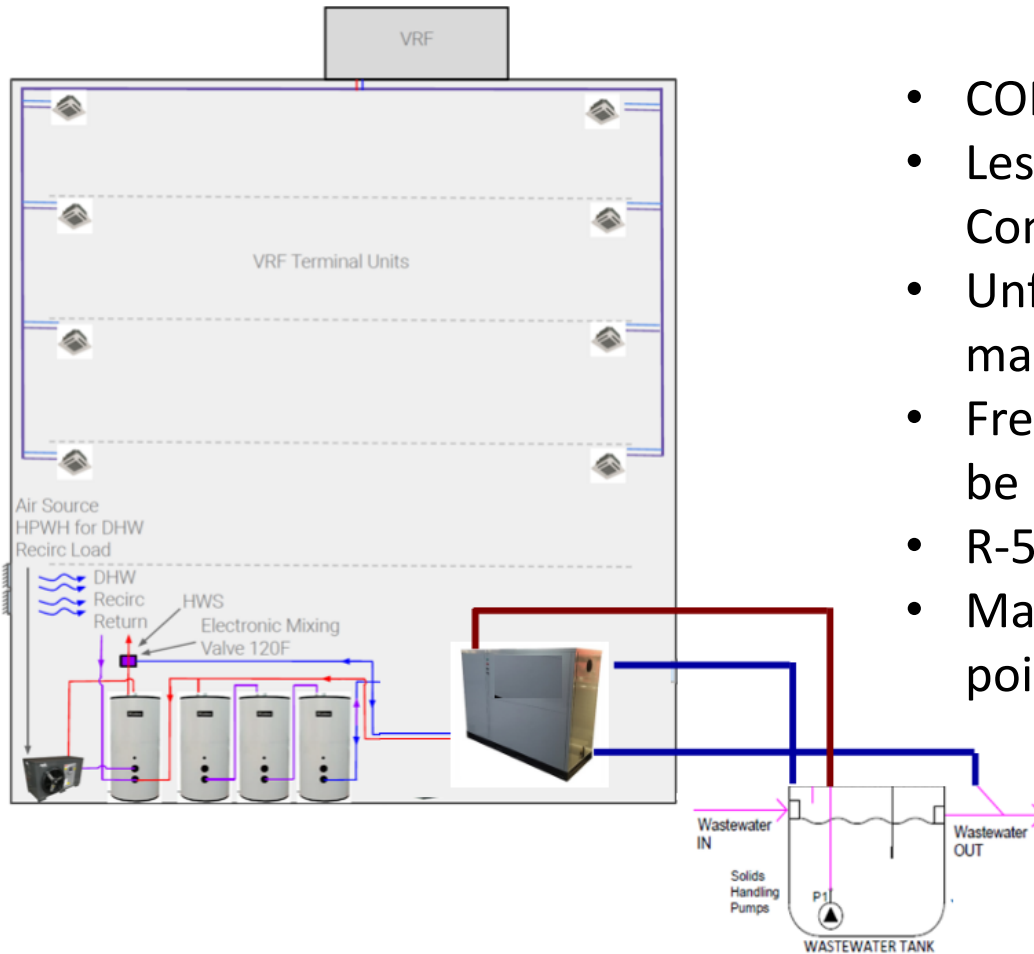

Solar DHW System

- Renewable
- High Installation Costs
- Market Unfamiliarity / Hesistance
- Freeze Protection Still Required
- May be paired with Heat Pump

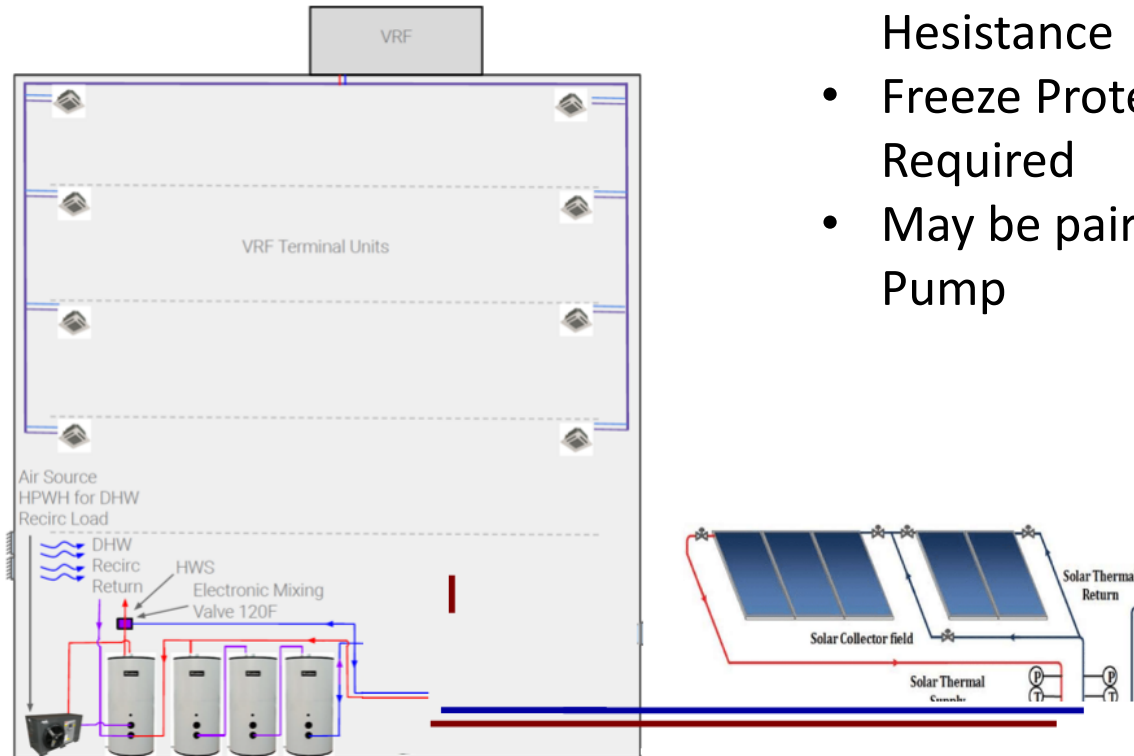

WARNING: THIS DRAWING SHOWS SUGGESTED PIPING CONFIGURATION AND OTHER DEVICES; CHECK WITH LOCAL CODES AND ORDINANCES FOR ADDITIONAL REQUIREMENTS.

SINGLE-PASS

THREE AIR TO WATER HEAT PUMPS, SINGLE TEMPERATURE
WITH FOUR VERTICAL STORAGE TANKS
AND ONE SWING TANK WITH RESISTIVE BACKUP / REHEAT

LEGEND		
	TEMPERATURE & PRESSURE RELIEF VALVE	
	PRESSURE RELIEF VALVE	
	CIRCULATING PUMP	
	TANK OR LINE TEMPERATURE CONTROL	

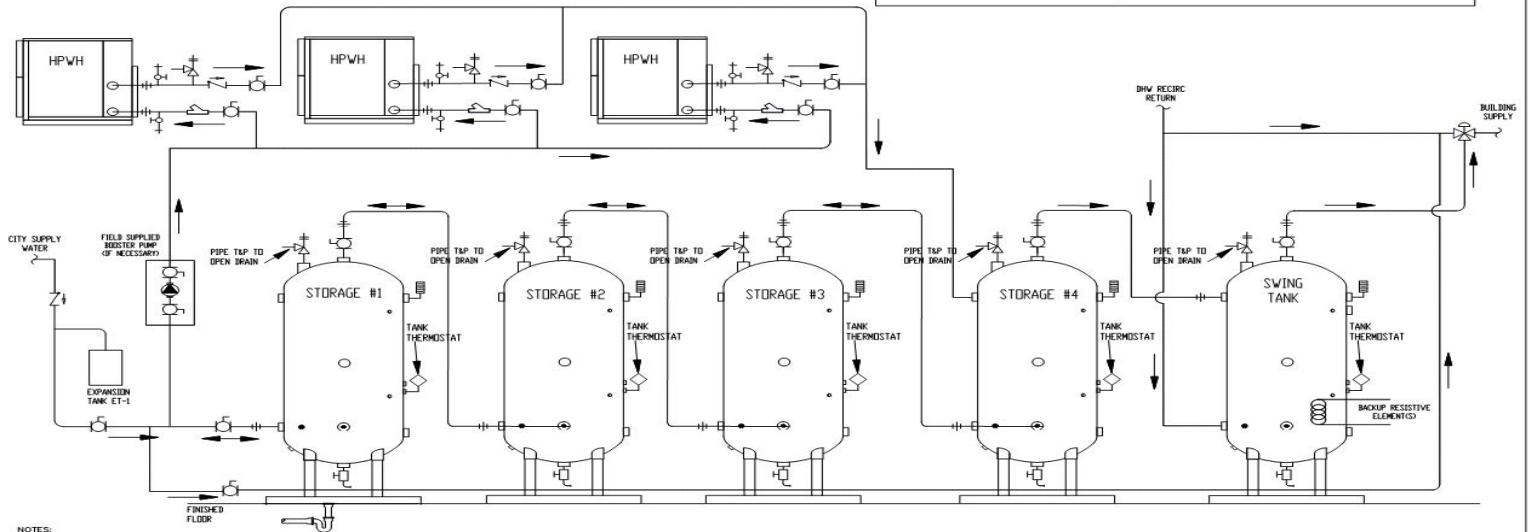

- NOTES:
- PREFERRED PIPING DIAGRAM.
 - THE TEMPERATURE AND PRESSURE RELIEF VALVE SETTING SHALL NOT EXCEED PRESSURE RATING OF ANY COMPONENT IN THE SYSTEM.
 - SERVICE VALVES ARE SHOWN FOR SERVICING UNIT. HOWEVER, LOCAL CODES SHALL GOVERN THEIR USAGE.

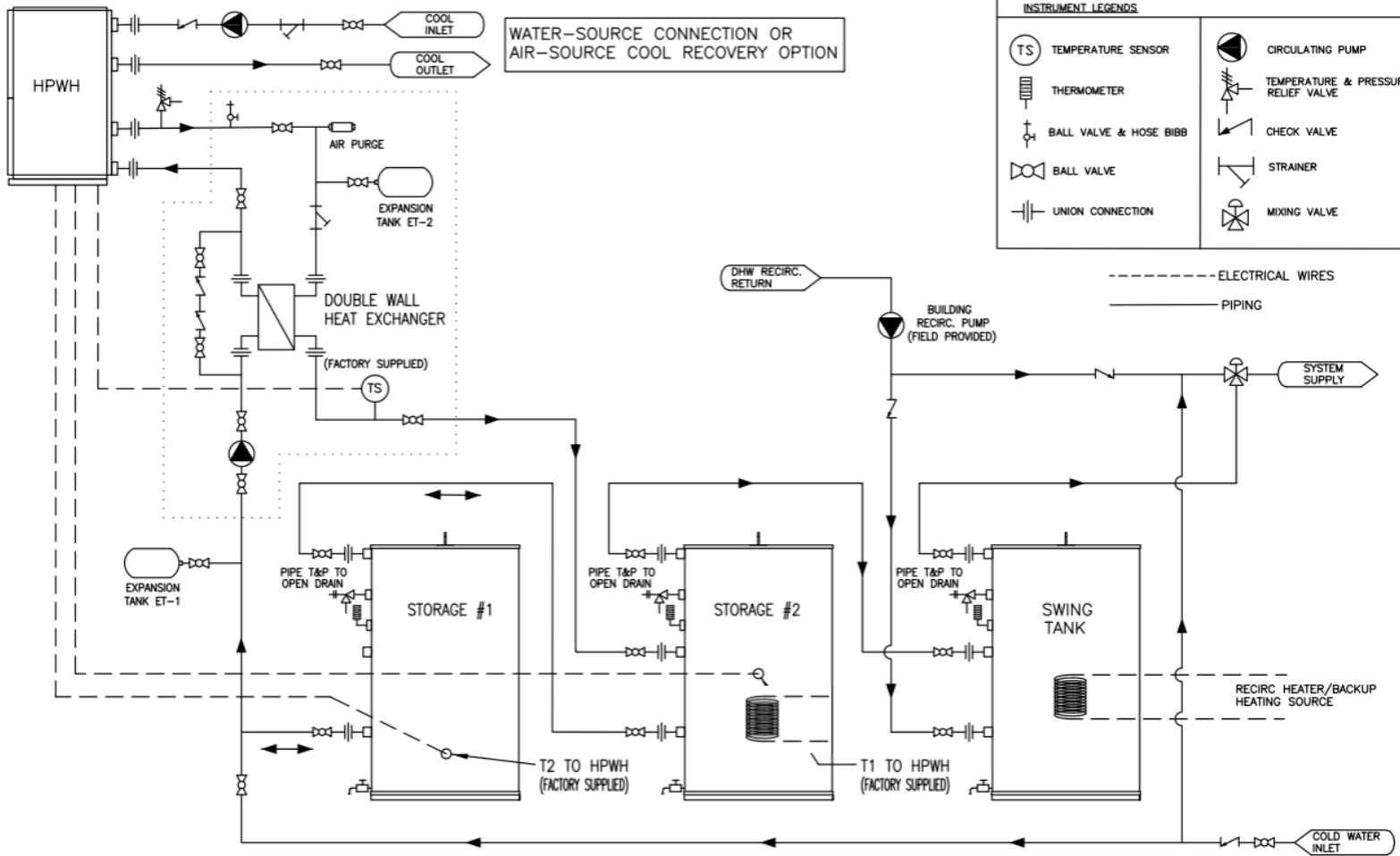

WATER-SOURCE CONNECTION OR
AIR-SOURCE COOL RECOVERY OPTION

INSTRUMENT LEGENDS			
(TS)	TEMPERATURE SENSOR		CIRCULATING PUMP
	THERMOMETER		TEMPERATURE & PRESSURE RELIEF VALVE
	BALL VALVE & HOSE BIBB		CHECK VALVE
	BALL VALVE		STRAINER
	UNION CONNECTION		MIXING VALVE

----- ELECTRICAL WIRES
 _____ PIPING

Other Design Considerations

• E

• S

• S

• C

• T

• Tying in w

- 4-P
- AS
- Siz
- He

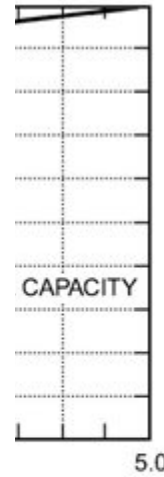
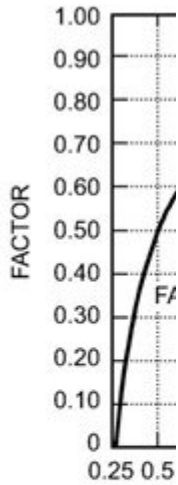

Fig.

ing

25
ce and Water

Other Design Considerations

- Refrigerant Phase Out Timeline

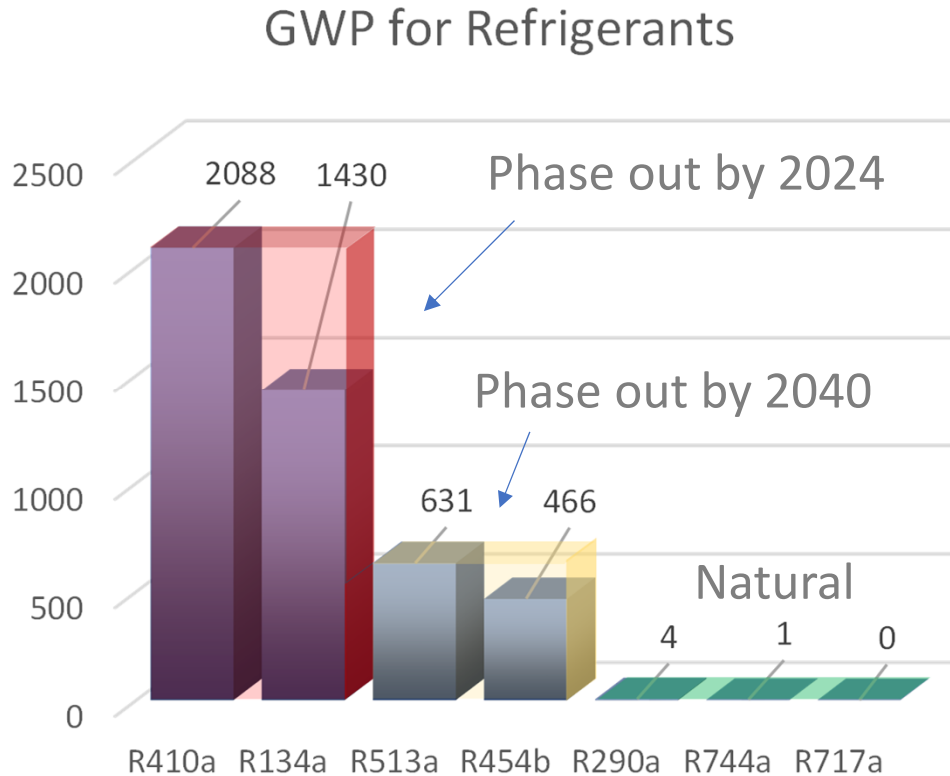

Questions?

