



PLUMBING
TECHNICAL SERVICES

Cast Iron Soil Pipe

History and Overview





Who is the Tech Team?



Brian South - MSME, MSTC
Technical Services Regional Manager (Rocky Mountains)
brian.south@mcwanepbgrp.com
(832) 428-4690



Ancient Plumbing Systems

Ancient Plumbing Systems

- Civilizations and populations grew
 - Need for sanitation increased
- Drainage ditches, clay, wood, brick, and lead pipe were all used before the cast iron pipe



China's Henan Province (2000 BC)



Ancient Rome (800 BC)

Babylonia – Iraq (4000 BC)

Birthplace of first known storm water drain system.

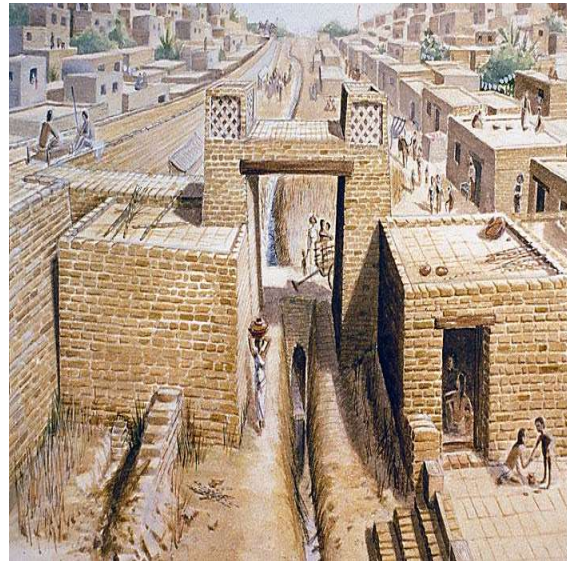

Orkney Islands (3200 BC)

Home of first lavatory like plumbing system.

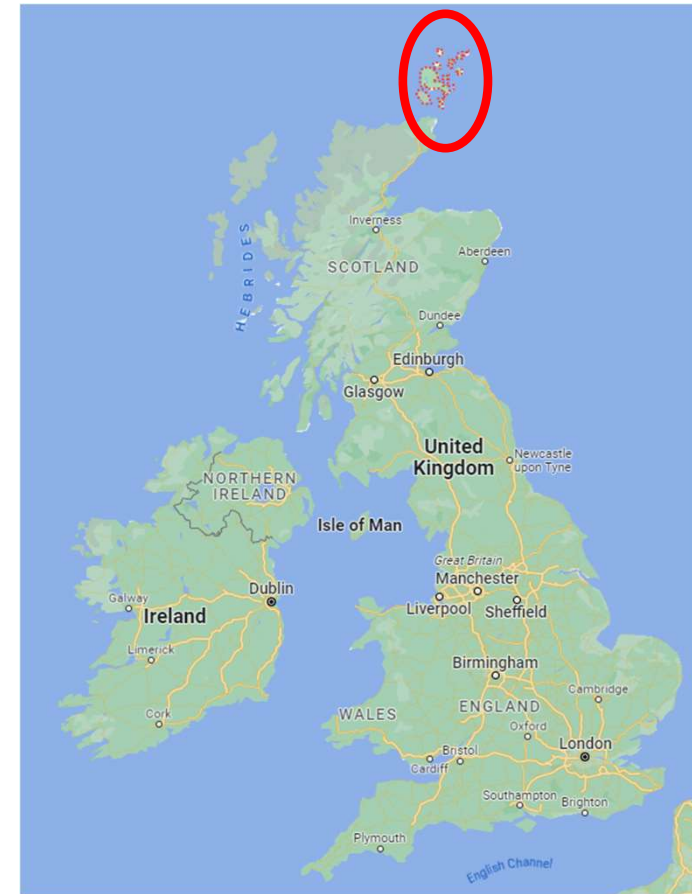

Indus River Valley – India (3000 BC)

First sanitation system connected nearly all citizens



Crete – The Minoans (3000-1000 BC)

The most advanced plumbing system until the Romans.

Bell/spigot clay pipes enabled siphoning. Drew the odor away from latrines.

This innovation was way ahead of its time! They also used storm water to flush systems



Greeks & Romans (800 BC – 400 AD)

Aqueducts and underground sewers were extensive.

Lead pipes began to be used to carry water as well. Some are still in use today.

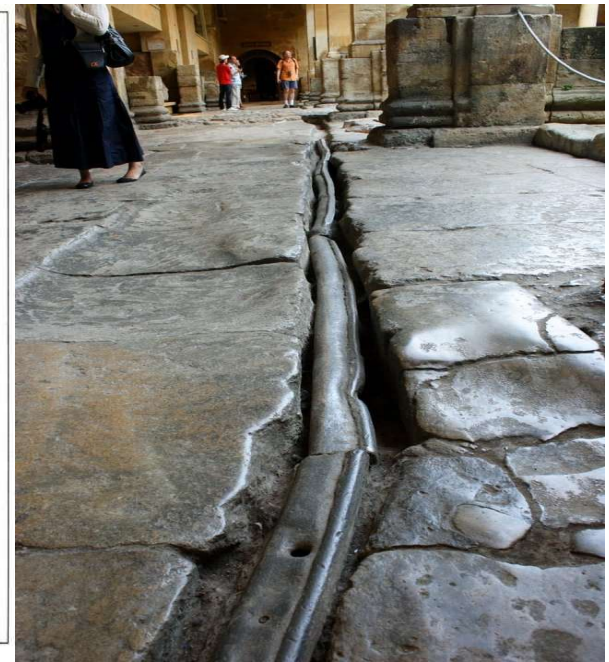
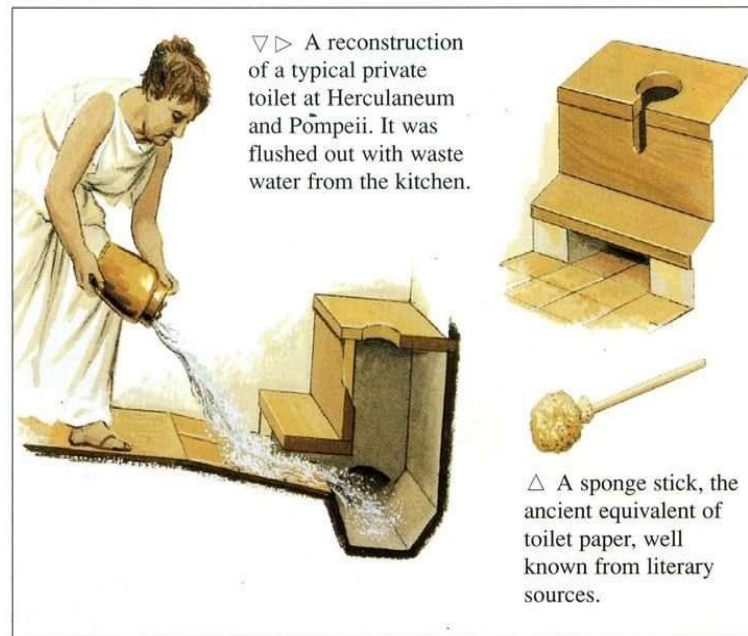

History: Wood Pipe

Hollowed logs used as early as 1300's in England were bell and spigot





WOODEN WATER PIPES,

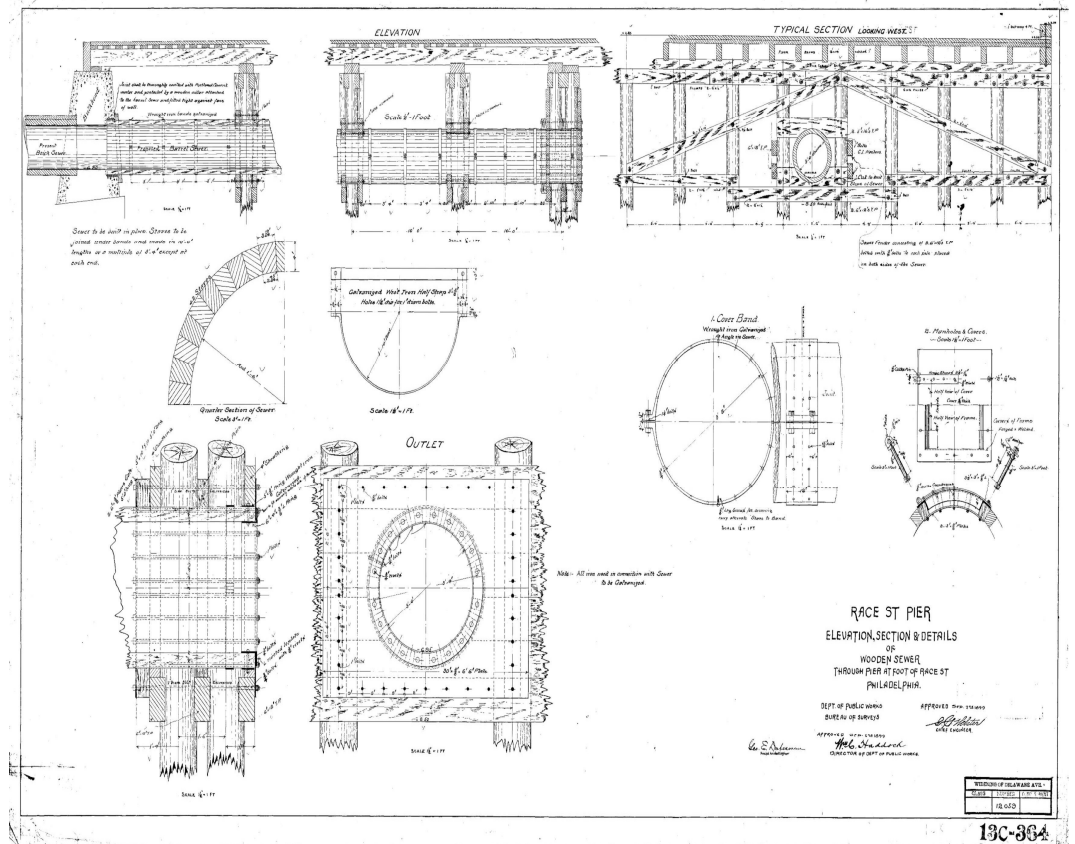



Old Chicago Water Main Installed in the Late 1800's

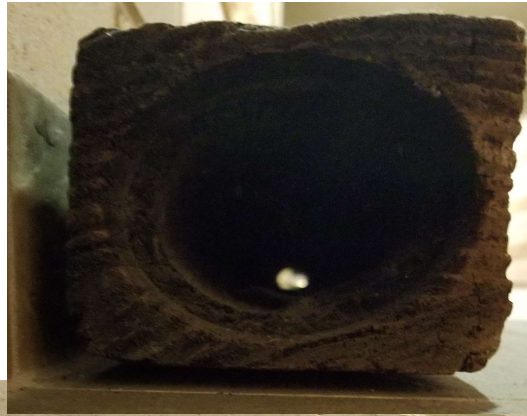



The octagon in the CHASE logo harkens back to log pipes laid by the Manhattan Company in the early 1800's

The Manhattan Company was formed to bring fresh water to New Yorkers.

Founders really wanted was to open a bank. Today its called JP Morgan Chase.



The Manhattan Company wooden pipes carried fresh water to more than 2,000 customers in lower Manhattan for 43 years

These wood pipes are still being unearthed today!



History of Cast Iron

Earliest History of Cast Iron

- First recorded use → Germany 1562, water fountain
- First full-scale cast iron pipe system used to distribute water in 1664 → Fountains of Versailles in France
 - Still in service today after 359 years!



History of Cast Iron in US

- The first cast-iron pipe manufactured in US in early 1800's
 - Foundry in Weymouth, New Jersey
 - Used for municipal water services
- Late 1880's foundries popped up all over US
 - Usually near natural resources
 - Pipe and many other products were manufactured for a multitude of purposes including sanitary systems









Emergence of Cast Iron Soil Pipe Industry

- **1785:** Bell (Hub) & Spigot joint invented by Sir Thomas Simpson (Lead & Oakum)
- **1890:** Cities continued to install water works and sewer systems at a rapid pace
- **1894:** 64 cast iron soil pipe foundries
- **1898:** 71 foundries (pressure and soil pipe)
 - 37 devoted to soil pipe in 13 states with capacity of 560,000 tons!
- **1900:** Alabama was one of largest soil pipe producers
 - 3rd largest, principle producer of iron ore, coal and limestone
- **1915:** Alabama contributed about 35 percent of the nation's soil pipe demand
- **1949:** Cast Iron Soil Pipe Institute (CISPI) was born



Members from 1949 -1999

- **Alabama Pipe Co.** – Anniston, AL
- **American Brass & Iron Foundry** – Oakland, CA
- **Anniston Foundry Co.** – Anniston, AL
- **Anniston Soil Pipe Co. Inc** – Anniston, AL
- **Attalla Pipe & Foundry Co.** – Attalla, AL
- **Buffalo Pipe & Foundry Co.** – Buffalo, NY
- **Central Foundry Co.** – New York, NY
- **Charlotte Pipe & Foundry Co.** – Charlotte, NC
- **Clay Bailey Mfg, Co.** – Kansas City, MO
- **Combustion Engineering Superheater Inc.** – Chattanooga, TN
- **Eastern Foundry Co.** – Boyetown, PA
- **East Penn Foundry Co.** – Macungie, PA
- **Emory Pipe & Foundry Co.** – Anniston, AL
- **Hajoca Corp.** – Lansdale, PA
- **T.C.King Pipe & Foundry Co.** – Anniston, AL
- **Reading Foundry Co.** – Reading, PA
- **Rich Mfg Co. of California** – Los Angeles, CA
- **Rudisill Foundry Co.** – Anniston, AL
- **Russell Pipe & Foundry Co.** – Alexander City, AL
- **Sanitary Co. of America** – Linfield, PA
- **Somerville Iron Works** – Somerville, NJ
- **Tyler Pipe & Foundry Co.** – Tyler, TX
- **Walker Foundry & Machine Co.** – Roanoke, VA
- **Williamstown Foundry Corp.** – Williamstown, NJ



Members from 1949 -1999

- **Alabama Pipe Co.** – Anniston, AL
- **American Brass & Iron Foundry** – Oakland, CA
- **Anniston Foundry Co.** – Anniston, AL
- **Anniston Soil Pipe Co. Inc** – Anniston, AL
- **Attalla Pipe & Foundry Co.** – Attalla, AL
- **Buffalo Pipe & Foundry Co.** – Buffalo, NY
- **Central Foundry Co.** – New York, NY
- **Charlotte Pipe & Foundry Co.** – Charlotte, NC
- **Clay Bailey Mfg, Co.** – Kansas City, MO
- **Combustion Engineering Superheater Inc.** – Chattanooga, TN
- **Eastern Foundry Co.** – Boyetown, PA
- **East Penn Foundry Co.** – Macungie, PA
- **Emory Pipe & Foundry Co.** – Anniston, AL
- **Hajoca Corp.** – Lansdale, PA
- **T.C.King Pipe & Foundry Co.** – Anniston, AL
- **Reading Foundry Co.** – Reading, PA
- **Rich Mfg Co. of California** – Los Angeles, CA
- **Rudisill Foundry Co.** – Anniston, AL
- **Russell Pipe & Foundry Co.** – Alexander City, AL
- **Sanitary Co. of America** – Linfield, PA
- **Somerville Iron Works** – Somerville, NJ
- **Tyler Pipe & Foundry Co.** – Tyler, TX
- **Walker Foundry & Machine Co.** – Roanoke, VA
- **Williamstown Foundry Corp.** – Williamstown, NJ



What is in the Cast Iron You Specify?

The Cast Iron Pipe Itself

- The cast iron pipe used today is typically called **Gray Cast Iron**

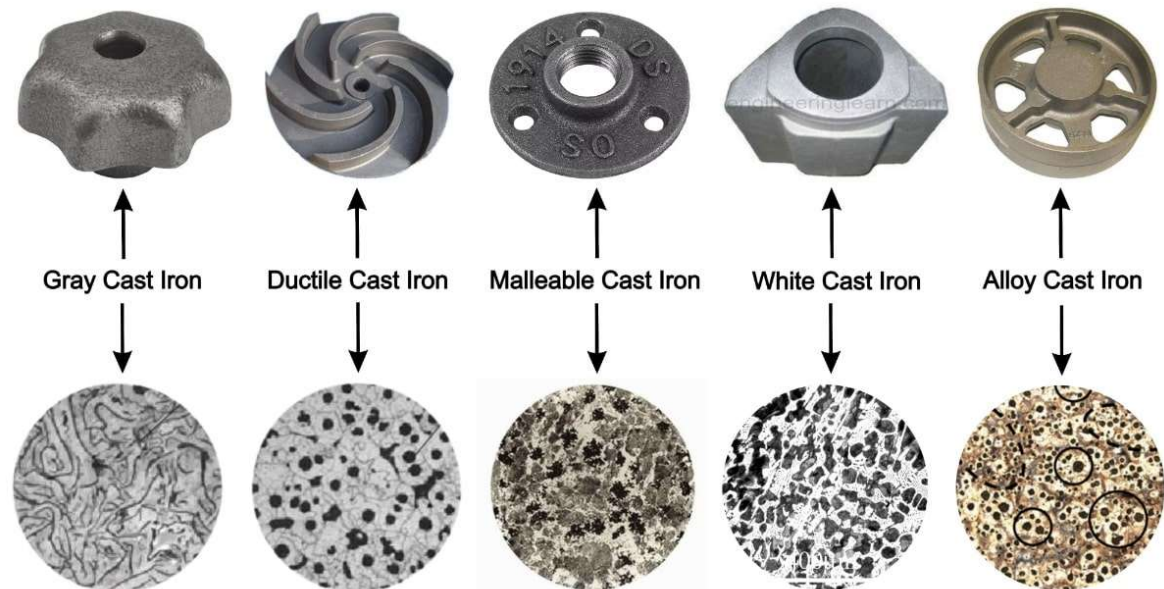

The Cast Iron Pipe Itself

- First cast iron was cast in **Horizontal Molds**
 - Un-even diameters & wall thicknesses
- 1845: **Vertical Molds** were commonly used
 - Pouring molten iron into a tub like structure
 - Cutting off the capped ends created the pipe
 - Un-even pipe diameters and thin walls
- 1918: **Centrifugally Cast** pipe was invented
 - Still used to this day
 - Precise amount of molten iron spun to shape
 - Consistent length and thickness of pipe

POURING IN TRUE CENTRIFUGAL CASTING

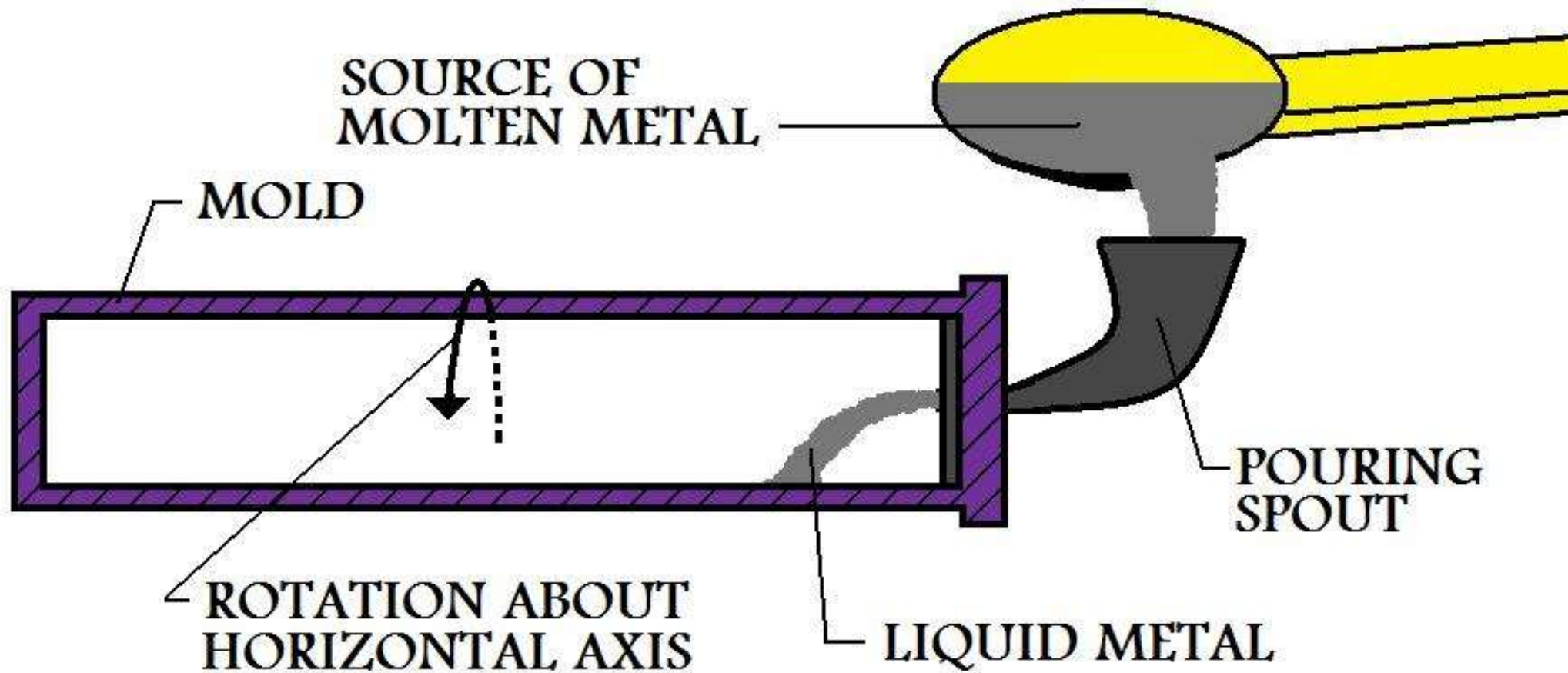

The Cast Iron Pipe Itself

- Presence/properties of carbon in cast iron pipe requires no additional coating
- CISPI 301, ASTM A888, and ASTM A74 only call for a coating “suitable for purpose”
- The asphalt is used for aesthetics and shipping

Cast Iron Ingredients



Carbon



Chromium



Copper



Iron



Manganese



Nickel



Silicon



Tin

Living Building Challenge

Component	Ingredient Name	%
Recycled Cast Iron	Carbon C	2.5 - 4.0
	Chromium (Cr)	0.01 - 1.5
	Copper (Cu)	0.01 -1.00
	Iron (Fe)	86.3 - 96.2
	Manganese (Mn)	0.2 - 1.1
	Nickel (Ni)	0.01 - 1.5
	Silicon (Si)	1.0 - 3.5
	Tin (Sn)	0.1 -0.15

Declare.

AB&I Cast Iron Soil Pipe and Fittings
ABI Foundry

Final Assembly: Oakland, CA, USA
Life Expectancy: 50 Years
End of Life Options: Salvageable/Reusable in its Entirety

Ingredients
Recycled Iron, Man

Declare.

Tyler Cast Iron Soil Pipe
Tyler Pipe

Final Assembly: Tyler, TX, USA
Life Expectancy: 50 Years
End of Life Options: Salvageable/Reusable in its Entirety, Recyclable (100%)

Living Bulk
ABI-0001
VOC Content
Declaratio

Ingredients:
Recycled Cast Iron: Carbon, Chromium, Copper, Iron, Manganese, Nickel, Silicon, Tin

Living Building Challenge Criteria:

TYP-1001
VOC Content: N/A
Declaration Status

Exp: 01 JUL 2018
VOC Emissions: N/A
 LBC Red List Free
 LBC Compliant
 Declared

MANUFACTURER RESPONSIBLE FOR LABEL ACCURACY
INTERNATIONAL LIVING FUTURE INSTITUTE™ declareproducts.com

Types of Cast Iron Soil Pipe

Types of Cast Iron Soil Pipe

Hub and Spigot

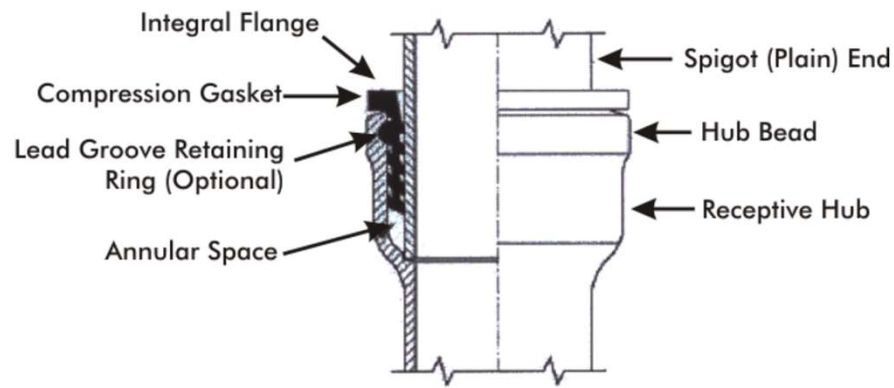

Types of Cast Iron Soil Pipe

NO-HUB



**NO-HUB PIPE,
TEN-FOOT LAYING LENGTH**

Part No.	Dia.	Per Bundle Piece	Bundle Wt.
006763	1½	54	1620
006770	2	54	1944
006787	3	36	1872
006794	4	27	1998
006800	5	24	2256
006817	6	18	1980
006824	8	15	2700
006831	10	8	2064
376583	12	6	1950
376590	15	3	1416



Types of Common Fittings

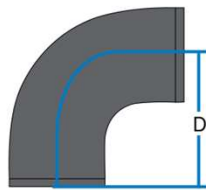

1/4 BEND

Part No.	Size	D	Wt.
00188	1½"	4¼	2
00190	2"	4½	3
00192	3"	5	4
00194	4"	5½	7
00196	5"	6½	9
00198	6"	7	14
00200	8"	8½	34
00218	4 x 3"	5½	6

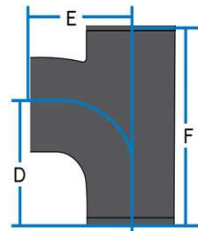

SANITARY TEE

Part No.	Size	D	E	F	Wt.
00806	1½"	4¼	4¼	6½	3
00808	2 x 1½"	4¼	4½	6 ⁵ / ₈	4
00810	2"	4½	4½	6 ⁷ / ₈	4
00812	3 x 1½"	4¼	5	6½	5
00814	3 x 2"	4½	5	6 ⁷ / ₈	4
00816	3"	5	5	8	5
00818	4 x 2"	4½	5½	6 ⁷ / ₈	7
00820	4 x 3"	5	5½	8	7
00822	4"	5½	5½	9 ¹ / ₈	11
00824	5 x 2"	5	6½	8½	9

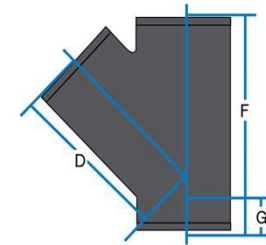

WYE

Part No.	Size	D	F	G	Wt.
01312	1½"	4	6	2	2
01314	2"	4 ⁵ / ₈	6 ⁵ / ₈	2	3
01316	3 x 2"	5 ⁵ / ₁₆	6 ⁵ / ₈	1½	4
01318	3"	5¾	8	2¼	6
01320	4 x 2"	6	6 ⁵ / ₈	1	6
01322	4 x 3"	6½	8	1 ¹¹ / ₁₆	7
01324	4"	7 ¹ / ₁₆	9½	2 ⁷ / ₁₆	8
01326	5 x 2"	7½	8 ¹ / ₁₆	1 ⁵ / ₁₆	7
01328	5 x 3"	8	9 ¹¹ / ₁₆	1 ¹¹ / ₁₆	9
01330	5 x 4"	8½	11 ³ / ₁₆	2 ⁷ / ₁₆	12
01332	5"	9½	12 ⁹ / ₁₆	3 ¹ / ₈	15
01334	6 x 2"	8¼	8 ⁵ / ₁₆	½	10
01336	6 x 3"	8¾	9¾	1¼	13
01338	6 x 4"	9¼	11 ³ / ₁₆	1 ⁵ / ₁₆	16
01340	6 x 5"	10¼	12½	2 ⁹ / ₁₆	17
01342	6"	10¾	14 ¹ / ₁₆	3 ⁵ / ₁₆	21
01344	8 x 2"	9 ³ / ₈	8½	¾	16
01346	8 x 3"	9 ¹³ / ₁₆	9 ⁵ / ₁₆	½	18

Types of Specialty Fittings

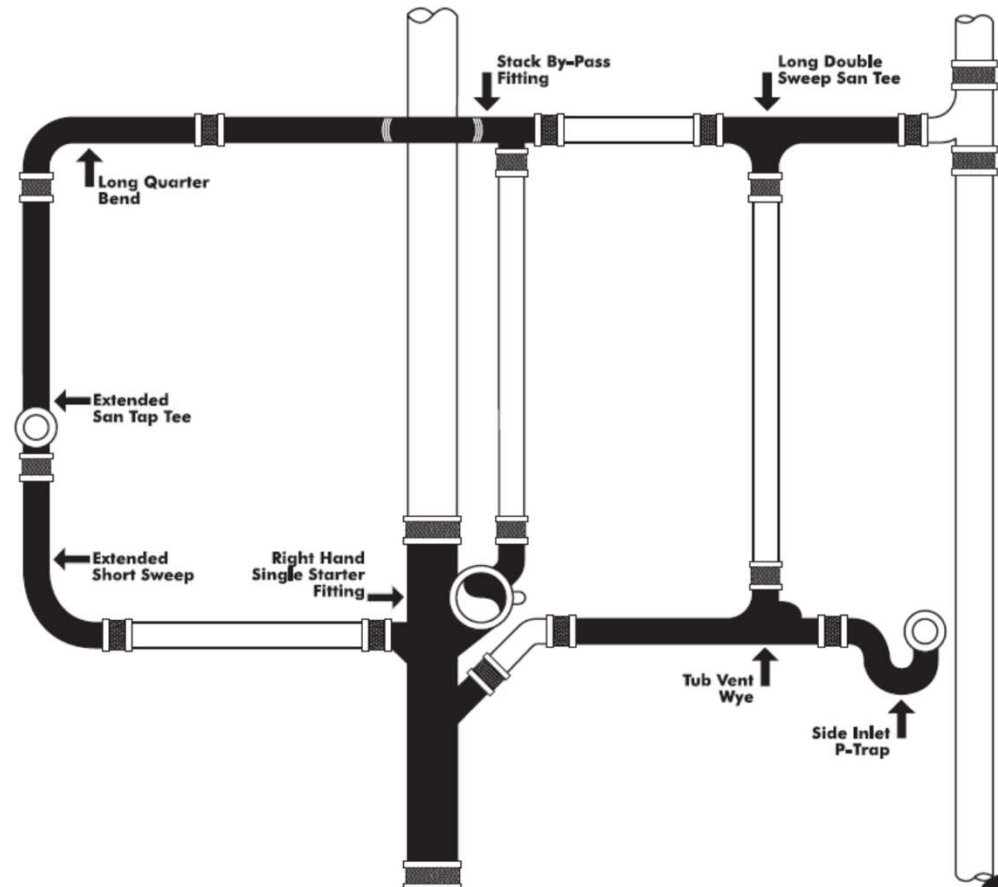



Cutting Methods

Cutting Methods





Sawzall Reciprocating Saw





Abrasive Cutting Machine (Chop Saw)





Snap Cutter (Manual)





Snap Cutter (Hydraulic)





Joining Methods

Joining Methods

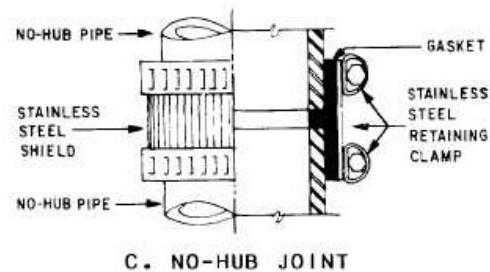
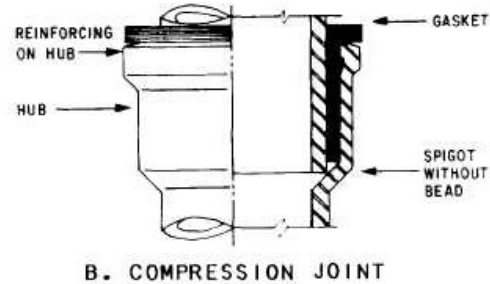
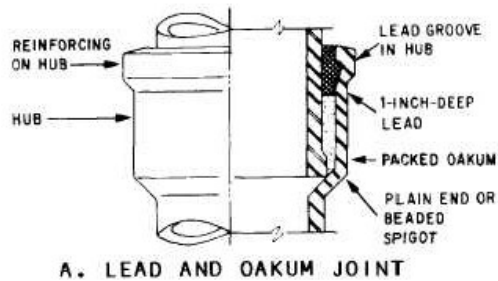

- Lead and oakum
- Compression gasket
- No-hub joint

Joining Methods

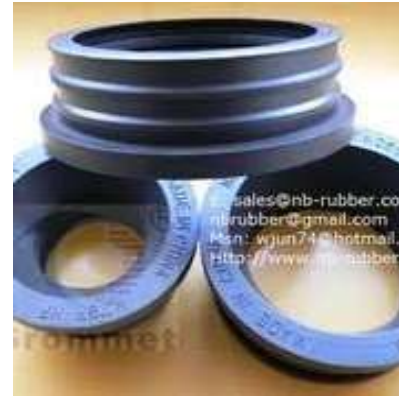



Lead & Oakum





Lead & Oakum



Compression Seal Gasket





Compression Seal Gasket



No-Hub Coupling



Standard and Heavy Duty



No-Hub Coupling

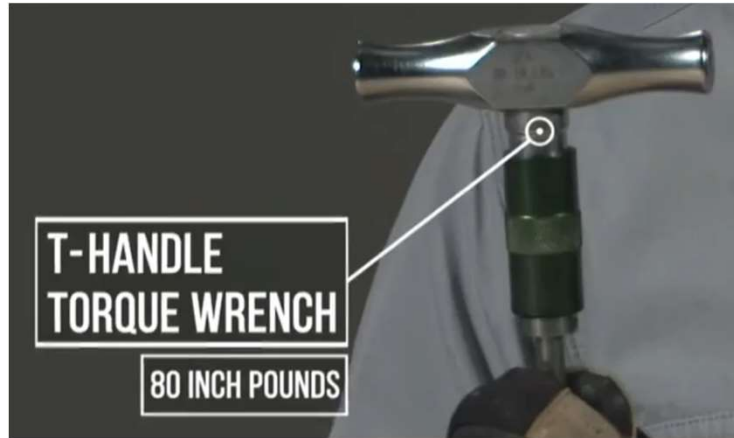



Codes & Standards

Codes & Standards

- ASTM A888 No-hub cast iron pipe and fittings
- CISPI 301 No-hub cast iron pipe and fittings
- ASTM A74 Hub / spigot cast iron pipe and fittings
- CISPI 310 Standard duty no-hub couplings
- ASTM C1277 Standard duty no-hub couplings
- ASTM C1540 Heavy duty no-hub couplings
- ASTM C564 Rubber gaskets
- ASTM C1460 Transition couplings



Codes & Standards



Each standard has similar requirements for materials, manufacturing, coating, marking, dimension, mechanical and chemical testing, sampling, and certification.

The ANNEX A1 includes additional specifications for situations where manufacturers employ third-party certifiers, or inspectors as a part of their own certification to the standards.

“Manufacturer” defined in our standards is “the entity who pours the metal.”

Codes & Standards

The Addition to the Standard Mandates 2 Main Things:

- 1) That all product sold have records (**going back 7 years!**) to verify compliance to the quality control requirements within these standards. This includes radioactivity screen.
- 2) A dimension and marking inspection of the manufacturer's finished product



Codes & Standards

Documents that You Can Ask for that Are Required by the Standards:

- Radiation screening records
- Mechanical testing records to verify tensile strength (>21,000 psi)
- Dimensional inspection records
- Certification letter from manufacturer – legal name and address of the one who pours the metal
- “Analysis of castings or test bars **AFTER** the time of production shall **NOT** be used as evidence of compliance with this specification” – CISPI 301



Cast Iron Usage

Cast Iron Soil Pipe Uses

- Today's uses are primarily in commercial construction for pipe and fittings
 - Sizes include 2,3,4,5,6,8,10,12 and 15-inch diameters.
- Pipe is installed within wall cavities in residential construction, hospitals, educational institutions, industrial and commercial applications
 - Used for tubs, lavatory and water closet fixtures

Cast Iron Soil Pipe Uses

- Waste lines are connected to a main soil stack and vent lines may also be tied (strapped or braced) in at a point above highest fixture
- Building or house drain, the lowest horizontal piping in the draining system, receives discharge from soil, waste and drainage pipes from within the building and discharges it to sewer

Design Considerations

- Sound deadening qualities
- Fire stopping & life safety
- 100% recycled content
- Hanger frequency less
- Rigidity (prefabrication)
- Higher temp range
- Vibration dampening joints
- Extended system life
- Durability
- Made with decades of experience
- Made and inspected to strict standards
- History of domestic manufacturers
- Constructability
- Environmentally responsible
- Expands and contracts WITH building
- Range of natural chemical resistance

Design Considerations

The Quiet House® System Noise Comparison

Rule of Thumb: Most perceive a 10 dB increase in sound level as being twice as loud.

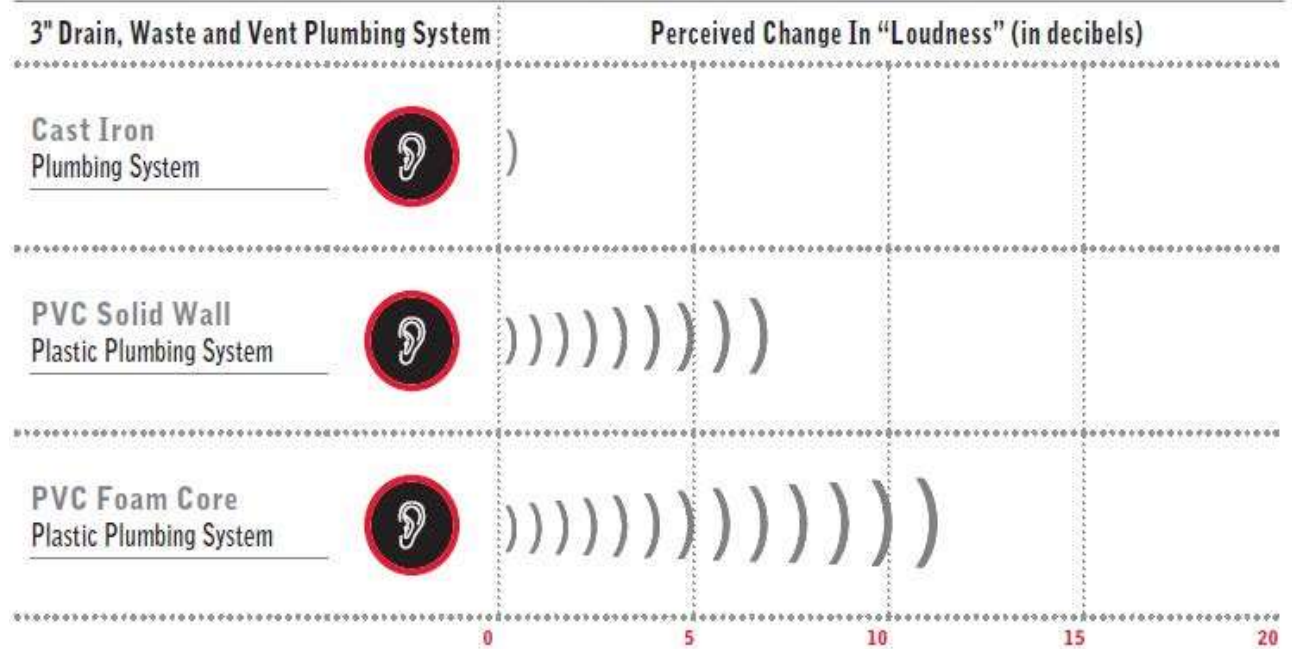

Installation Considerations

- Hanger within 18” of joint
- Horizontal pipe of 5” or greater must be braced at **every change of direction for THRUST restraint.**
- No special trench requirements to bury
- High Temperatures
- Fire stopping
- Sound sensitive installation, an advantage over other materials
- No expansion / contraction issues

Factors Influencing DWV Systems

Pressures:

- Less water introduced into DWV System (**#1 ISSUE**)
- Changes to venting
- Increase in chemicals down DWV
- Changes in municipality chemistry
- Increased environmental regulations (less water)

Possible Issues:

- More stoppages – due to lack of flow
- Possible increase in corrosion (hot, dry climate and stagnant water)
- Pitch issues

Conclusion

- Time tested
- Made and tested to standard
- Iron chemically verified
- Screened for radiation
- Tensile strength tested
- Inspected to standards
- Superior sound containment
- Corrosion resistance
- Fire resistive
- Meets codes
 - ICC/UPC
- Strength and durability

Future

- Today, cast iron pipe used for a variety of installations
 - Both above and below ground
 - **Preferred** DWV material for the many benefits this product offers
- Foundry methods have improved
 - Largely unchanged for many years
- Better scrap metal → unequaled quality in today's pipes and fittings



The Plumber Protects the Health of the Nation





Thank you for your time!

Questions?



Brian South - MSME, MSTC

Technical Services Regional Manager (Rocky Mountains)

brian.south@mcwanepbgrp.com

(832) 428-4690